



Secure AVR BLE IoT Node - Hardware User Guide

Secure AVR BLE IoT Node - Hardware User Guide

Introduction

This is the hardware user guide for the Secure AVR[®] BLE IoT Node field engagement board, based on the ATtiny1617, a high performance tinyAVR[®] 8-bit Microcontroller. The board is a hardware platform to address the IoT markets.

Secure AVR BLE IoT Node incorporates ATtiny1617 microcontroller, RN4871 Bluetooth[®] 4.2 Low Energy full certified Module, and CryptoAuthentication[™] device ATECC508A, and 3-axis accelerometer with temperature sensor to demonstrate a complete solution for a typical IoT end node.

Supported by the Atmel START and Atmel Studio development platform. It is provided with fully documented software and hardware which will significantly reduce design complexity and the time-to-market.

The users can refer to the source code and firmware user guide available at Atmel START <http://start.atmel.com/>.

Features

- Bluetooth connectivity through the RN4871 Bluetooth 4.2 Low Energy full certified Module
- Node authentication by onboard ATECC508A
- LED indicators for operational status
- QTouch[®] Button
- 3-axis accelerometer with integrated temperature sensor
- USB or CR2032 coin cell powered
- Programming via single-wire UPDI

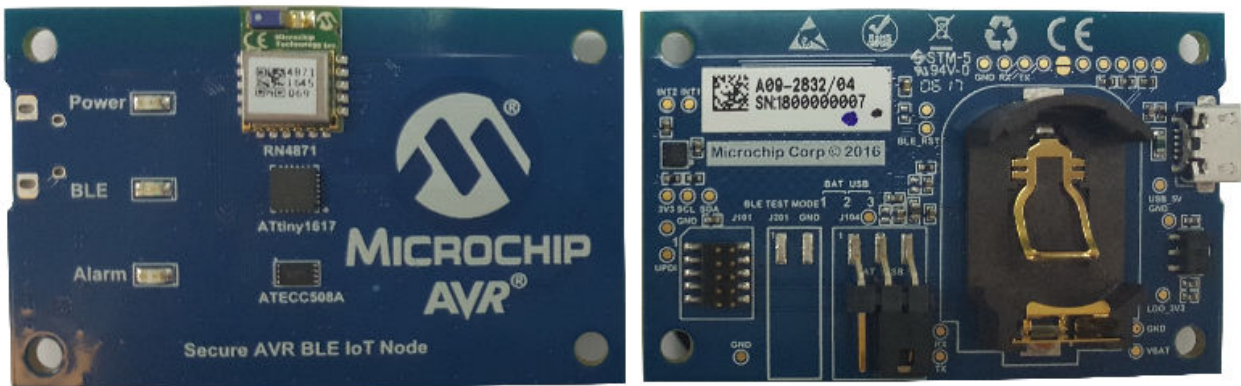

Table of Contents

Introduction.....	1
Features.....	1
1. Prerequisites.....	3
2. Overview.....	4
2.1. System Overview.....	4
2.2. Block Diagram.....	5
2.3. Operation Guide.....	6
3. Hardware Details.....	7
3.1. Microcontroller.....	7
3.2. Bluetooth Low Energy Module.....	7
3.3. Security and Authentication.....	8
3.4. 3-axis Accelerometer.....	9
3.5. Power Supply.....	10
3.6. User Interface.....	10
3.6.1. Touch Button.....	10
3.6.2. Status LEDs.....	10
3.7. UPDI Programming Interface.....	11
4. Firmware.....	12
4.1. ATtiny1617 Default Firmware.....	12
4.1.1. Firmware Programming.....	12
4.2. RN4871 BLE Module Firmware.....	14
4.2.1. Firmware Programming.....	14
4.2.2. RN4871 Bluetooth Module Configuration.....	16
5. Revision History.....	17
The Microchip Web Site.....	18
Customer Change Notification Service.....	18
Customer Support.....	18
Microchip Devices Code Protection Feature.....	18
Legal Notice.....	19
Trademarks.....	19
Quality Management System Certified by DNV.....	20
Worldwide Sales and Service.....	21

1. Prerequisites

- Hardware
 - Secure AVR® BLE IoT Node Field Engagement Board
 - One Micro-USB Type-B cable or CR2032 Coin Cell
 - Atmel-ICE
- Software
 - Atmel Studio 7
 - Secure AVR BLE IoT Node firmware
 - Secure AVR BLE IoT Node APP
- General
 - Mobile phone with Bluetooth function

2. Overview

2.1 System Overview

The board carries the RN4871 BLE module which provides a complete solution to implement Bluetooth 4.2 Low Energy connectivity, the crypto authentication device ATECC508A provides highly secure hardware-based key storage, a 3-axis accelerometer with integrated temperature sensor. The LEDs and the touch button function as the board user interface.

Secure AVR BLE IoT Node - Hardware User Guide

Figure 2-1. Overview of the Secure AVR BLE IoT Node Board

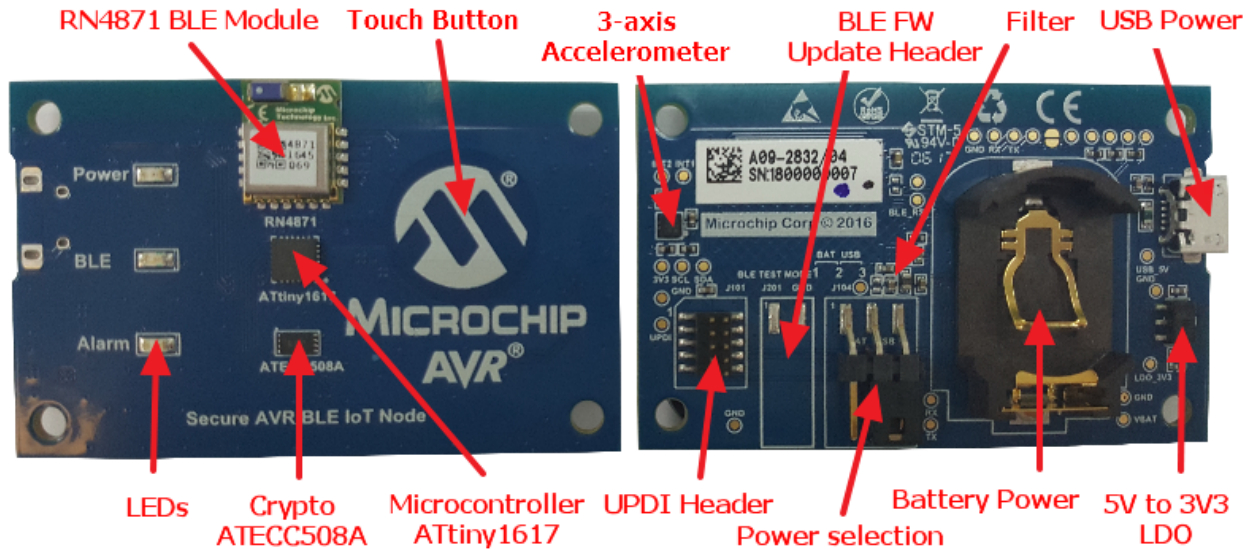

2.2 Block Diagram

Figure 2-2. Block Diagram of the Secure AVR BLE IoT Node Board

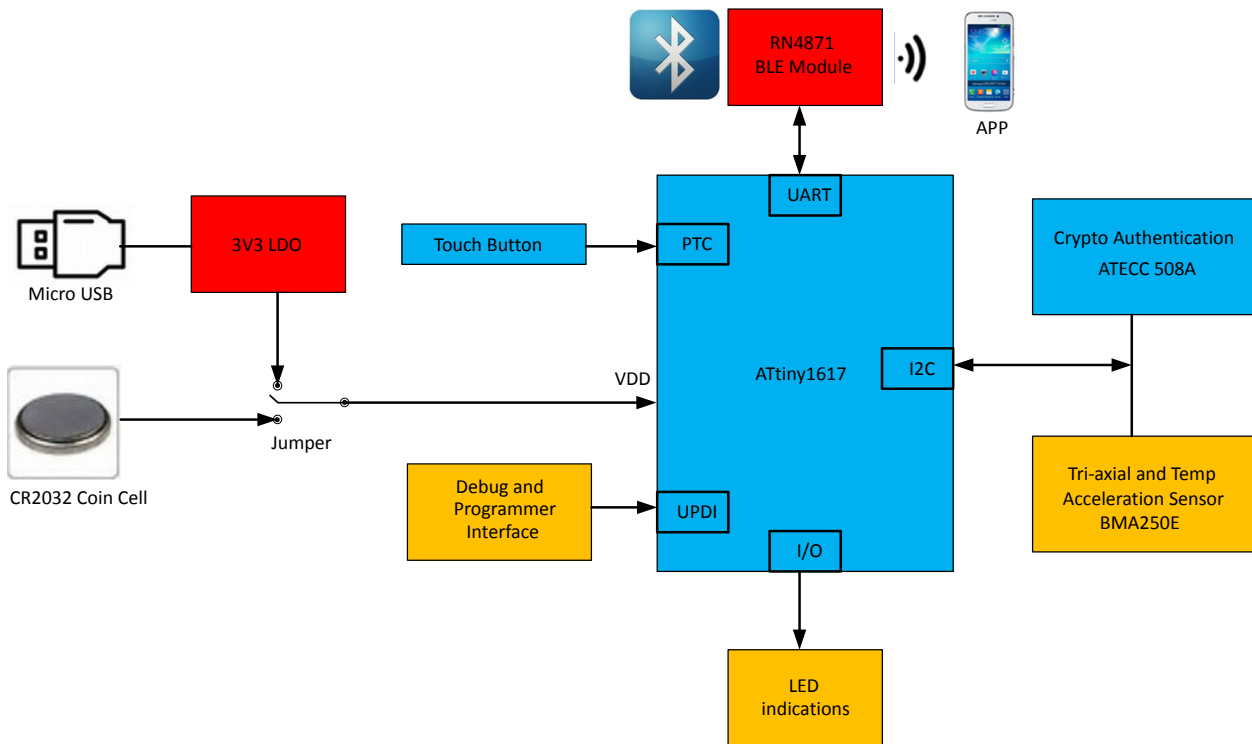

Secure AVR BLE IoT Node demonstrates an IoT Node together with the associated firmware and mobile phone application. It provide a complete solution on how to securely establish communication between a Node and Mobile phone, and read the sensor data via Bluetooth.

2.3 Operation Guide

As shown in the block diagram above, the Secure AVR BLE IoT Node field engagement board is powered using a CR2032 coin cell or USB. An LDO regulates the 5V USB voltage to 3.3V. A jumper is used to select the power supply to the entire system. After power is ON, the field engagement board goes through the initialization phase where the MCU's internal system, RN4871 BLE Module, and sensor are initialized. When the BLE module is in the broadcasting state the BLE indicator blinks once per 3 seconds. Run the "Secured AVR BLE IoT Node" application to find and connect to the nearby Secure AVR BLE IoT Node. The application is available on both iOS and Android™.

When the connection is established between the BLE Module and mobile phone, the BLE LED starts to blink twice per 1.5 seconds. After this node is authenticated using the ATECC508A CryptoAuthentication module the user can navigate to different Android or iOS App screens to check the sensor values. If the active Secure AVR BLE IoT Node is disconnected from the Android or iOS App, the kit enters low power mode. For the list of app screens supported, refer to the Getting Started Guide in the enclosed package.

3. Hardware Details

3.1 Microcontroller

ATtiny1617 is an 8-bit tinyAVR microcontroller with 16KB Flash, 2KB SRAM, and 256B of EEPROM in a 14-, 20-, and 24-pin package.

The microcontroller uses the latest technologies from Microchip with a flexible and low-power architecture including Event System and SleepWalking, accurate analog features, and advanced peripherals. Capacitive touch interfaces with proximity sensing and driven shield are supported with the integrated QTouch Peripheral Touch Controller.

Figure 3-1. Schematic for the Microcontroller

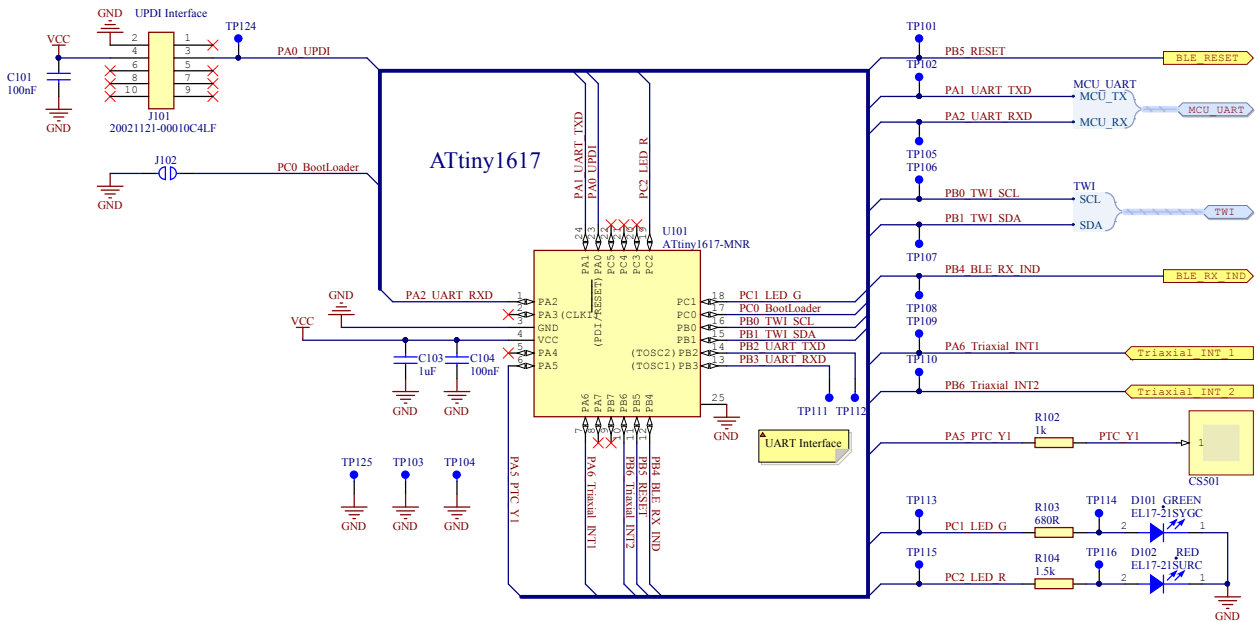

3.2 Bluetooth Low Energy Module

Microchip's RN4871 Bluetooth Low Energy Module is a fully-certified Bluetooth Smart module offering Bluetooth 4.2 connectivity in compact form factor. The host ATtiny1617 MCU uses ASCII commands over UART to control and exchange data with the RN4871 BLE module.

Figure 3-2. Schematic for the BLE Module

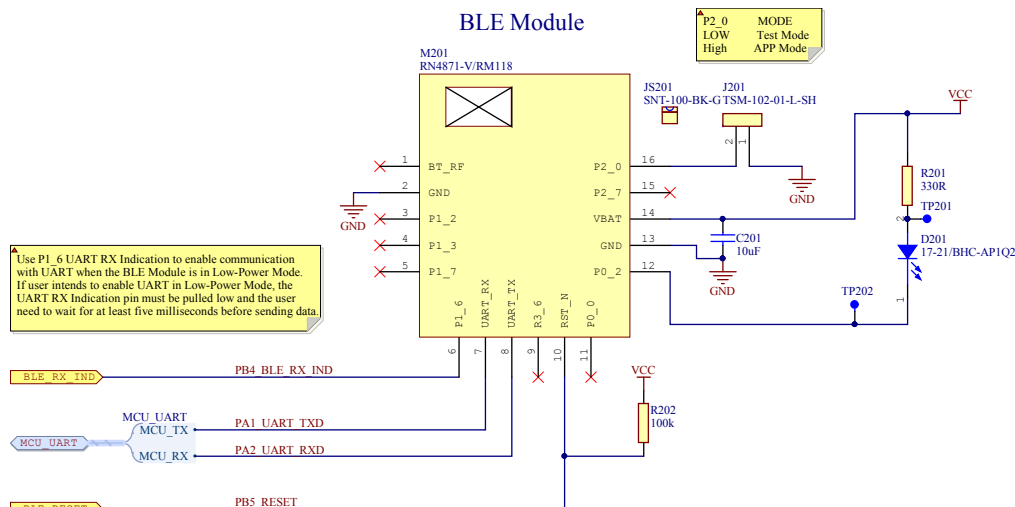

The P1_6 Pin (UART RX Indication) of the module is used to wake the module from low power mode, switching from running at 32kHz to 16MHz clock and enables the UART. The P1_6 pin must be pulled low and the user needs to wait for at least five milliseconds before sending the data.

The P2_0 pin of the module is used to select the working mode, application mode, or test mode. By default, it is pulled high internally to select the application mode. It can be pulled low using the 1x2 connector J201, which is a 2.54mm pitch surface mount header, if you need to update the firmware or change EEPROM settings. The jumper position on the connector should be connected as shown in the table below.

Table 3-1. BLE Module Working Mode Select Jumper Position

Jumper Position	Description
1-2	Test Mode
-	Application Mode

For detailed information about how to update the firmware and configure the RN4871 BLE module, refer to the RN4871 BLE Module Default Firmware section.

Table 3-2. Pin Map for the BLE Module

Signal Name	MCU pin
PA1_UART_TXD	PA1
PA2_UART_RXD	PA2
PB4_BLE_RX_IND	PB4
PB5_RESET	PB5

3.3 Security and Authentication

In the board, the authentication is handled by the Microchip ATECC508A CryptoAuthentication device. This device is used for authentication of the node. ATECC508A employs ultra-secure hardware-based cryptographic key storage and cryptographic countermeasures which are more secure than software-

Secure AVR BLE IoT Node - Hardware User Guide

based key storage. The ATECC508A device provides certificates to ATtiny1617 MCU through a Two-Wire interface (TWI).

For more information about the security and authentication, refer to the Secure AVR BLE IoT Node Software User Guide.

Figure 3-3. Schematic for the Crypto ATECC508A

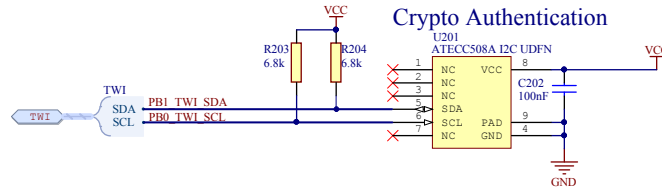

Table 3-3. Pin Map for the Crypto ATECC508A

Signal Name	MCU Pin
PB0_TWI_SCL	PB0
PB1_TWI_SDA	PB1

3.4 3-axis Accelerometer

A BMA250E triaxial acceleration sensor from Bosch Sensortec provides acceleration data in three perpendicular axes to ATtiny1617 MCU through a Two-Wire interface (TWI). The integrated temperature sensor is used for estimation of the ambient temperature. In addition, it provides two interrupt pins; INT1 and INT2.

Figure 3-4. Schematic for the Triaxial Acceleration Sensor

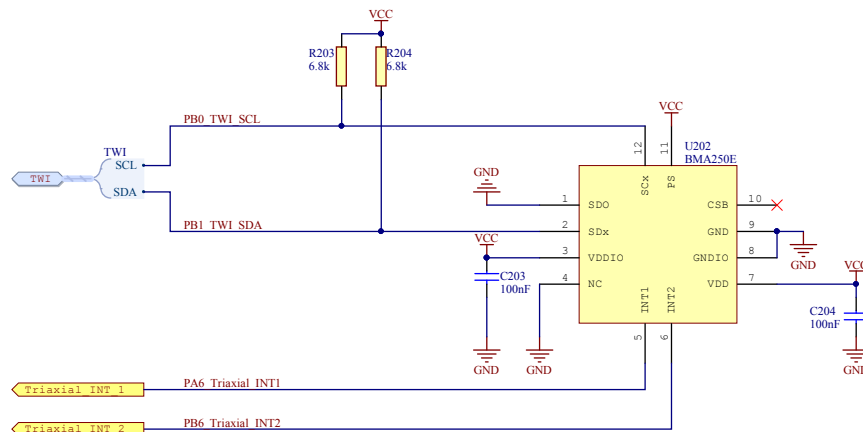

Table 3-4. Pin Map for the 3-axis Accelerometer

Signal Name	MCU Pin
PB0_TWI_SCL	PB0
PB1_TWI_SDA	PB1
PA6_Triaxial_INT1	PA6
PB6_Triaxial_INT2	PB6

3.5 Power Supply

As shown in the figure below, the board is supplied with +5V from either the Micro-USB interface with ESD protection or +3V from a CR2032 coin cell. The applied LDO can source out 250mA @ 3.3V system power. The 1x3 connector is 2.54mm pitch surface mount header and used to select power source. The jumper position on the connector should be connected per the table below.

Figure 3-5. Power Supply for the System

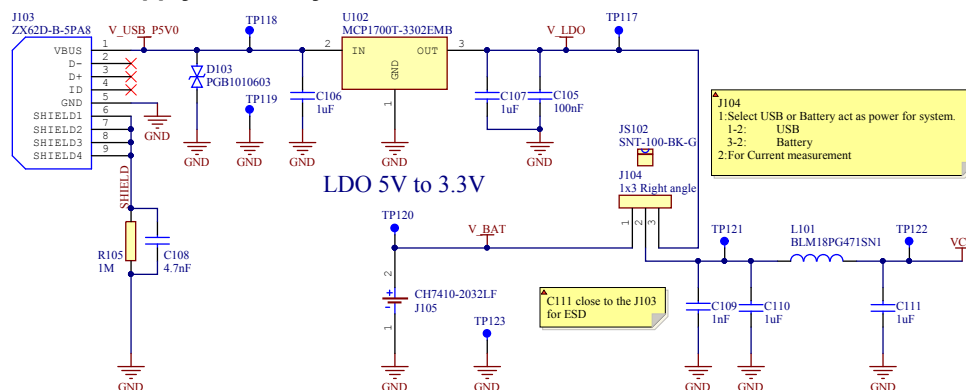

Table 3-5. Power Select Jumper Position

Jumper Options	Description
1-2	CR2032 coin cell as power supply
3-2	USB as power supply regulated to 3.3V

3.6 User Interface

3.6.1 Touch Button

The Peripheral Touch Controller (PTC) acquires signals in order to detect touch on capacitive sensors. The external capacitive touch sensor is formed on the PCB, and the sensor electrodes are connected to the analog front end of the PTC through the I/O pins in the device. The PTC supports both self-capacitance and mutual-capacitance sensors.

On the board, the touch button is designed to work in the self-capacitance mode, the PTC requires only one pin (Y-line) for the touch sensor. The diameter of the sensor electrodes is 12 millimeter, which is similar to a finger. The 1kΩ series resistor is helpful to prevent ESD damage to the design.

Figure 3-6. Schematic for the Touch Button

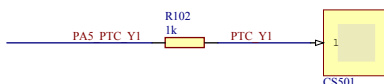

Table 3-6. Pin Map for the Touch Button

Signal Name	MCU Pin
PA5_PTC_Y1	PA5

3.6.2 Status LEDs

The Secure AVR BLE IoT Node field engagement board supports three status LEDs.

Secure AVR BLE IoT Node - Hardware User Guide

1. PWR LED: The power LED indicates the status of the MCU. The LED is lit when the MCU is active. The initial state is ON.
2. Alarm LED: The Alarm LED blinks when the user taps the board. The initial state is OFF.
3. BLE LED: The BLE LED blinks once per 3 seconds when there is no active BLE connection. During active BLE connection, the LED blinks twice per 1.5 seconds. The initial state is OFF.

The PWR LED and Alarm LED is controlled independently by two GPIOs on the microcontroller. The BLE LED is controlled by the RN4871 module. For the detailed explanation of the BLE LED status, download the RN4871 data sheet and User Guide documents available at the product page <http://www.microchip.com/wwwproducts/en/RN4871>.

Figure 3-7. Status LEDs

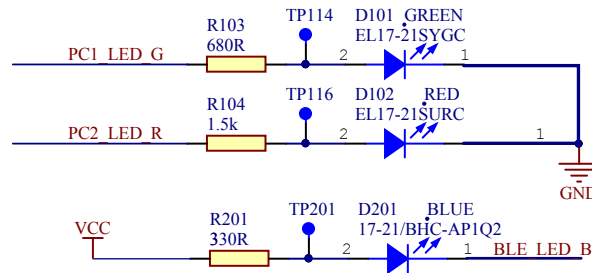

The detailed GPIO pin definition is shown in the table below.

Table 3-7. Pin Map for the LEDs

LEDs Name	Signal Name	MCU Pin	BLE Module Pin
PWR LED	PC1_LED_G	PC1	-
Alarm LED	PC2_LED_R	PC2	-
BLE LED	BLE_LED_B	-	P0_2

3.7 UPDI Programming Interface

Unified Program and Debug Interface (UPDI) is a Microchip proprietary interface for external programming and on-chip debugging of a device.

The 2x5 connector for the interface is a 1.27mm pitch surface mount header.

Figure 3-8. UPDI Interface

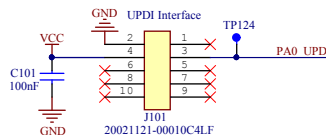

Table 3-8. Pin Map for ATtiny1617 UPDI Interface

Signal name	Header pin	MCU Pin
GND	2	GND
PA0_UPDI	3	PA0
VCC	4	VCC

4. Firmware

4.1 ATtiny1617 Default Firmware

The ATtiny1617 device on the board comes preprogrammed with the firmware described in the Software User Guide.

4.1.1 Firmware Programming

The default firmware is available in the zip and named 'ATtiny1617_Secure_AVR_BLE_IoT_Node.elf'.

The ATtiny1617 supports UPDI (Unified Program and Debug Interface), which is a Microchip proprietary interface for external programming and on-chip debugging of a device. It is possible for the user to reprogram the device using an Atmel-ICE or similar tool with UPDI support.

Secure AVR BLE IoT Node - Hardware User Guide

Figure 4-1. Connection of the Board and Programmer



Note: The AVR port of the Atmel-ICE must be used for programming and debugging the ATtiny1617 device.

The programming interface of Atmel Studio is shown in the figure below:

Figure 4-2. Programming Interface in Atmel Studio

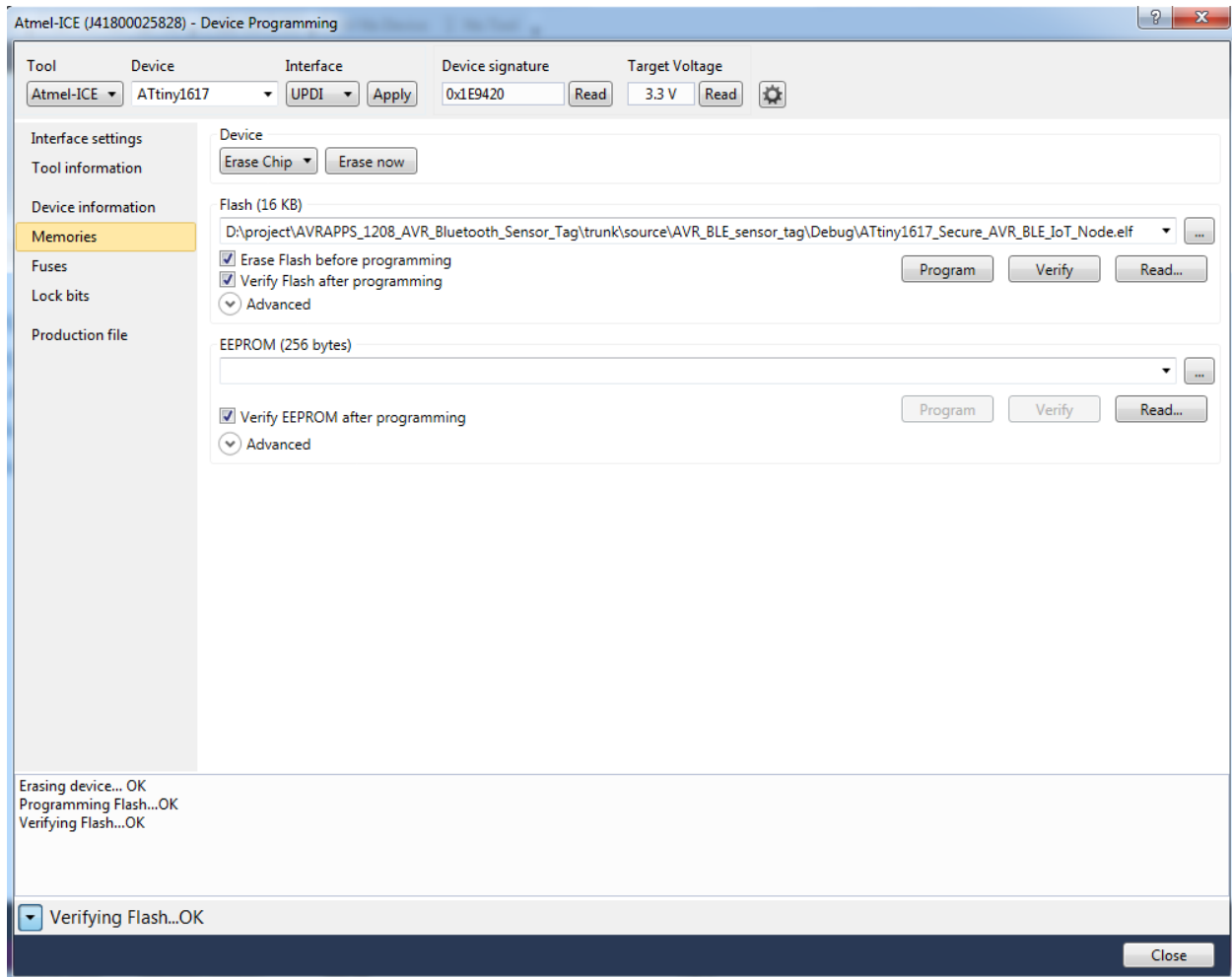

4.2 RN4871 BLE Module Firmware

A default firmware V1.18.3 is preprogrammed in the RN4871 Bluetooth Low Energy 4.2 RF module. The firmware for the RN4871 can be updated using a PC tool `isupdate.exe` over the USB port.

The latest RN4871 firmware images and `isupdate.exe` firmware load PC tool are available from the product page at the <http://www.microchip.com/wwwproducts/en/RN4871>.

4.2.1 Firmware Programming

To update the firmware on the RN4871 follow the instructions below.

- Download the firmware zip file from the product web page and extract the content. The firmware images are included.
- Download the firmware update tool zip file from the product web page and extract the content. It contains the `Isupdate.exe` utility.
- Short the 1pin and 2pin of the J201 connector using the 2.54mm jumper.
- Connect the Secure AVR BLE IoT Node board to the PC host using the USB to UART converter cable.

Secure AVR BLE IoT Node - Hardware User Guide

Figure 4-3. Connection of the Board and USB to the UART Converter Cable

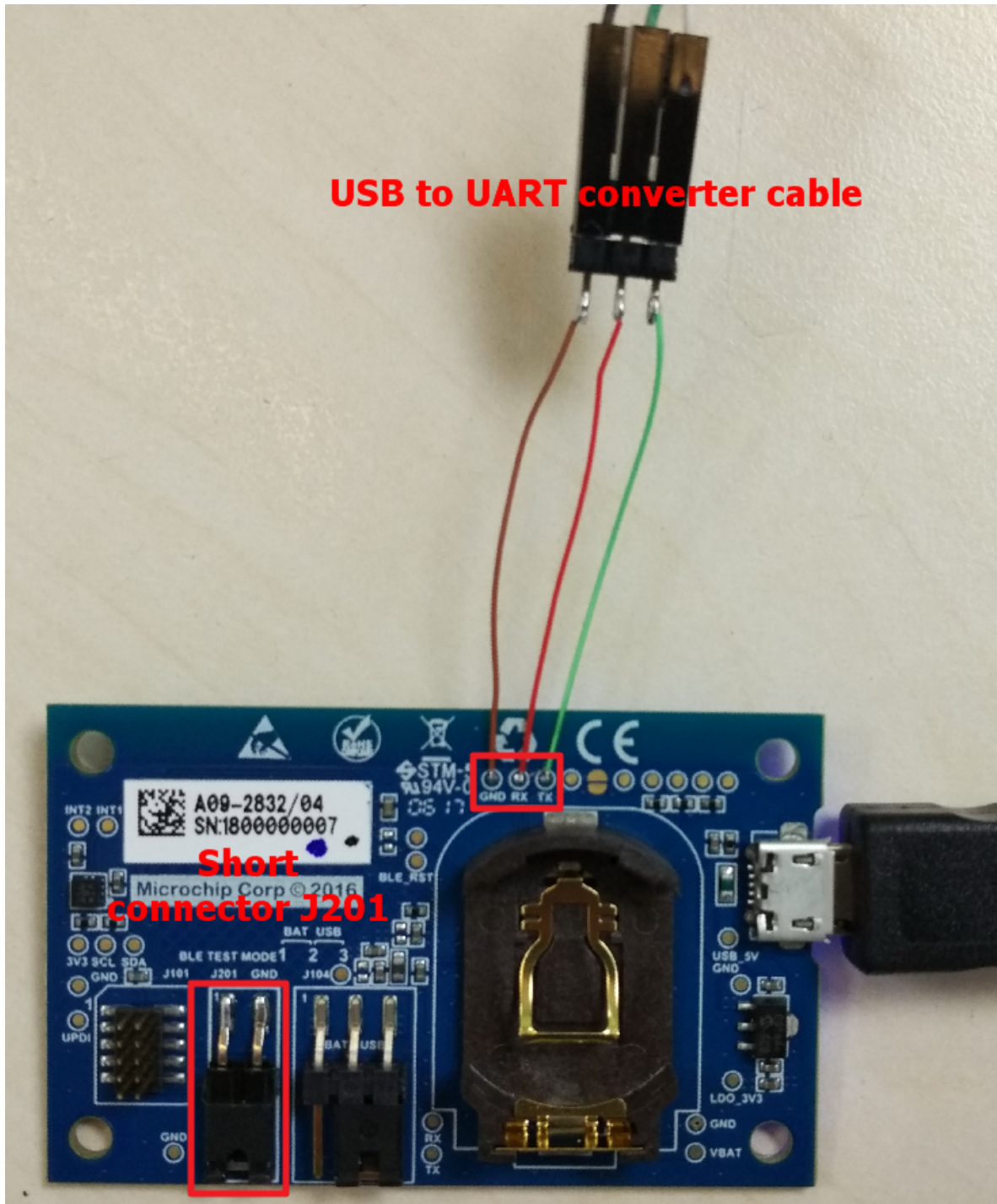

- Launch the lupdate.exe application.
 - Select the COM port used by the Secure AVR BLE IoT Node board
 - Verify that the other settings (baudrate, memory type/subtype, address) are set as shown in the figure below

Figure 4-4. Isupdate.exe Firmware Update Utility

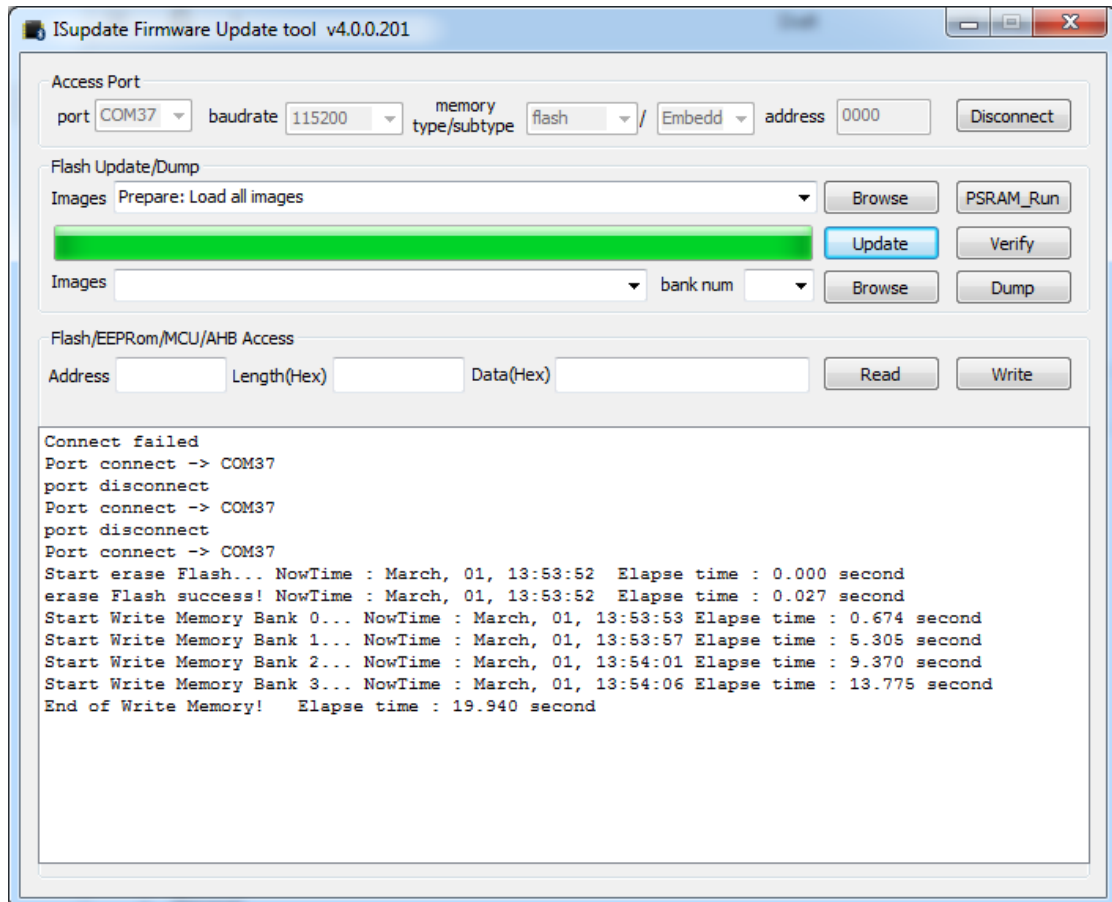

- Click the Connect button and verify that the “port connect → COMxx” is displayed in the text box
- Click the Browse button and load all images in the firmware zip file, then click the Update button. Verify that the firmware update has completed successfully. The “End of Write Memory” message is displayed in the text box.

4.2.2 RN4871 Bluetooth Module Configuration

A default configuration is preprogrammed in the RN4871 module.

There are two ways to send the configuration commands to RN4871 for Configuration. One is through the ATtiny1617 on board, the default configuration firmware is available in the zip and named 'ATtiny1617_Secure_AVR_BLE_IoT_Node_BLE_Conf.elf'. Another is through the ASCII commands over the USB.

After downloading the BLE module configuration firmware into ATtiny1617, wait until the Alarm LED is turned ON to confirm the BLE module is configured successfully.

For detailed explanation of the RN4871 commands and specifications, download the RN4871 data sheet and user guide documents available at the product page <http://www.microchip.com/wwwproducts/en/RN4871>.

5. Revision History

Doc. Rev.	Date	Comments
A	06/2017	Initial document release

The Microchip Web Site

Microchip provides online support via our web site at <http://www.microchip.com/>. This web site is used as a means to make files and information easily available to customers. Accessible by using your favorite Internet browser, the web site contains the following information:

- **Product Support** – Data sheets and errata, application notes and sample programs, design resources, user's guides and hardware support documents, latest software releases and archived software
- **General Technical Support** – Frequently Asked Questions (FAQ), technical support requests, online discussion groups, Microchip consultant program member listing
- **Business of Microchip** – Product selector and ordering guides, latest Microchip press releases, listing of seminars and events, listings of Microchip sales offices, distributors and factory representatives

Customer Change Notification Service

Microchip's customer notification service helps keep customers current on Microchip products. Subscribers will receive e-mail notification whenever there are changes, updates, revisions or errata related to a specified product family or development tool of interest.

To register, access the Microchip web site at <http://www.microchip.com/>. Under "Support", click on "Customer Change Notification" and follow the registration instructions.

Customer Support

Users of Microchip products can receive assistance through several channels:

- Distributor or Representative
- Local Sales Office
- Field Application Engineer (FAE)
- Technical Support

Customers should contact their distributor, representative or Field Application Engineer (FAE) for support. Local sales offices are also available to help customers. A listing of sales offices and locations is included in the back of this document.

Technical support is available through the web site at: <http://www.microchip.com/support>

Microchip Devices Code Protection Feature

Note the following details of the code protection feature on Microchip devices:

- Microchip products meet the specification contained in their particular Microchip Data Sheet.
- Microchip believes that its family of products is one of the most secure families of its kind on the market today, when used in the intended manner and under normal conditions.
- There are dishonest and possibly illegal methods used to breach the code protection feature. All of these methods, to our knowledge, require using the Microchip products in a manner outside the operating specifications contained in Microchip's Data Sheets. Most likely, the person doing so is engaged in theft of intellectual property.
- Microchip is willing to work with the customer who is concerned about the integrity of their code.

Secure AVR BLE IoT Node - Hardware User Guide

- Neither Microchip nor any other semiconductor manufacturer can guarantee the security of their code. Code protection does not mean that we are guaranteeing the product as “unbreakable.”

Code protection is constantly evolving. We at Microchip are committed to continuously improving the code protection features of our products. Attempts to break Microchip’s code protection feature may be a violation of the Digital Millennium Copyright Act. If such acts allow unauthorized access to your software or other copyrighted work, you may have a right to sue for relief under that Act.

Legal Notice

Information contained in this publication regarding device applications and the like is provided only for your convenience and may be superseded by updates. It is your responsibility to ensure that your application meets with your specifications. MICROCHIP MAKES NO REPRESENTATIONS OR WARRANTIES OF ANY KIND WHETHER EXPRESS OR IMPLIED, WRITTEN OR ORAL, STATUTORY OR OTHERWISE, RELATED TO THE INFORMATION, INCLUDING BUT NOT LIMITED TO ITS CONDITION, QUALITY, PERFORMANCE, MERCHANTABILITY OR FITNESS FOR PURPOSE. Microchip disclaims all liability arising from this information and its use. Use of Microchip devices in life support and/or safety applications is entirely at the buyer’s risk, and the buyer agrees to defend, indemnify and hold harmless Microchip from any and all damages, claims, suits, or expenses resulting from such use. No licenses are conveyed, implicitly or otherwise, under any Microchip intellectual property rights unless otherwise stated.

Trademarks

The Microchip name and logo, the Microchip logo, AnyRate, AVR, AVR logo, AVR Freaks, BeaconThings, BitCloud, CryptoMemory, CryptoRF, dsPIC, FlashFlex, flexPWR, Heldo, JukeBlox, KeeLoq, KeeLoq logo, Klear, LANCheck, LINK MD, maXStylus, maXTouch, MediaLB, megaAVR, MOST, MOST logo, MPLAB, OptoLyzer, PIC, picoPower, PICSTART, PIC32 logo, Prochip Designer, QTouch, RightTouch, SAM-BA, SpyNIC, SST, SST Logo, SuperFlash, tinyAVR, UNI/O, and XMEGA are registered trademarks of Microchip Technology Incorporated in the U.S.A. and other countries.

ClockWorks, The Embedded Control Solutions Company, EtherSynch, Hyper Speed Control, HyperLight Load, IntelliMOS, mTouch, Precision Edge, and Quiet-Wire are registered trademarks of Microchip Technology Incorporated in the U.S.A.

Adjacent Key Suppression, AKS, Analog-for-the-Digital Age, Any Capacitor, AnyIn, AnyOut, BodyCom, chipKIT, chipKIT logo, CodeGuard, CryptoAuthentication, CryptoCompanion, CryptoController, dsPICDEM, dsPICDEM.net, Dynamic Average Matching, DAM, ECAN, EtherGREEN, In-Circuit Serial Programming, ICSP, Inter-Chip Connectivity, JitterBlocker, KlearNet, KlearNet logo, Mindi, MiWi, motorBench, MPASM, MPF, MPLAB Certified logo, MPLIB, MPLINK, MultiTRAK, NetDetach, Omniscient Code Generation, PICDEM, PICDEM.net, PICkit, PICTail, PureSilicon, QMatrix, RightTouch logo, REAL ICE, Ripple Blocker, SAM-ICE, Serial Quad I/O, SMART-I.S., SQI, SuperSwitcher, SuperSwitcher II, Total Endurance, TSHARC, USBCheck, VariSense, ViewSpan, WiperLock, Wireless DNA, and ZENA are trademarks of Microchip Technology Incorporated in the U.S.A. and other countries.

SQTP is a service mark of Microchip Technology Incorporated in the U.S.A.

Silicon Storage Technology is a registered trademark of Microchip Technology Inc. in other countries.

GestIC is a registered trademark of Microchip Technology Germany II GmbH & Co. KG, a subsidiary of Microchip Technology Inc., in other countries.

All other trademarks mentioned herein are property of their respective companies.

© 2017, Microchip Technology Incorporated, Printed in the U.S.A., All Rights Reserved.

ISBN: 978-1-5224-1827-6

Quality Management System Certified by DNV

ISO/TS 16949

Microchip received ISO/TS-16949:2009 certification for its worldwide headquarters, design and wafer fabrication facilities in Chandler and Tempe, Arizona; Gresham, Oregon and design centers in California and India. The Company's quality system processes and procedures are for its PIC[®] MCUs and dsPIC[®] DSCs, KEELOQ[®] code hopping devices, Serial EEPROMs, microperipherals, nonvolatile memory and analog products. In addition, Microchip's quality system for the design and manufacture of development systems is ISO 9001:2000 certified.

Worldwide Sales and Service

AMERICAS	ASIA/PACIFIC	ASIA/PACIFIC	EUROPE
<p>Corporate Office 2355 West Chandler Blvd. Chandler, AZ 85224-6199 Tel: 480-792-7200 Fax: 480-792-7277 Technical Support: http://www.microchip.com/support Web Address: www.microchip.com</p> <p>Atlanta Duluth, GA Tel: 678-957-9614 Fax: 678-957-1455</p> <p>Austin, TX Tel: 512-257-3370</p> <p>Boston Westborough, MA Tel: 774-760-0087 Fax: 774-760-0088</p> <p>Chicago Itasca, IL Tel: 630-285-0071 Fax: 630-285-0075</p> <p>Dallas Addison, TX Tel: 972-818-7423 Fax: 972-818-2924</p> <p>Detroit Novi, MI Tel: 248-848-4000</p> <p>Houston, TX Tel: 281-894-5983</p> <p>Indianapolis Noblesville, IN Tel: 317-773-8323 Fax: 317-773-5453 Tel: 317-536-2380</p> <p>Los Angeles Mission Viejo, CA Tel: 949-462-9523 Fax: 949-462-9608 Tel: 951-273-7800</p> <p>Raleigh, NC Tel: 919-844-7510</p> <p>New York, NY Tel: 631-435-6000</p> <p>San Jose, CA Tel: 408-735-9110 Tel: 408-436-4270</p> <p>Canada - Toronto Tel: 905-695-1980 Fax: 905-695-2078</p>	<p>Asia Pacific Office Suites 3707-14, 37th Floor Tower 6, The Gateway Harbour City, Kowloon</p> <p>Hong Kong Tel: 852-2943-5100 Fax: 852-2401-3431</p> <p>Australia - Sydney Tel: 61-2-9868-6733 Fax: 61-2-9868-6755</p> <p>China - Beijing Tel: 86-10-8569-7000 Fax: 86-10-8528-2104</p> <p>China - Chengdu Tel: 86-28-8665-5511 Fax: 86-28-8665-7889</p> <p>China - Chongqing Tel: 86-23-8980-9588 Fax: 86-23-8980-9500</p> <p>China - Dongguan Tel: 86-769-8702-9880</p> <p>China - Guangzhou Tel: 86-20-8755-8029</p> <p>China - Hangzhou Tel: 86-571-8792-8115 Fax: 86-571-8792-8116</p> <p>China - Hong Kong SAR Tel: 852-2943-5100 Fax: 852-2401-3431</p> <p>China - Nanjing Tel: 86-25-8473-2460 Fax: 86-25-8473-2470</p> <p>China - Qingdao Tel: 86-532-8502-7355 Fax: 86-532-8502-7205</p> <p>China - Shanghai Tel: 86-21-3326-8000 Fax: 86-21-3326-8021</p> <p>China - Shenyang Tel: 86-24-2334-2829 Fax: 86-24-2334-2393</p> <p>China - Shenzhen Tel: 86-755-8864-2200 Fax: 86-755-8203-1760</p> <p>China - Wuhan Tel: 86-27-5980-5300 Fax: 86-27-5980-5118</p> <p>China - Xian Tel: 86-29-8833-7252 Fax: 86-29-8833-7256</p>	<p>China - Xiamen Tel: 86-592-2388138 Fax: 86-592-2388130</p> <p>China - Zhuhai Tel: 86-756-3210040 Fax: 86-756-3210049</p> <p>India - Bangalore Tel: 91-80-3090-4444 Fax: 91-80-3090-4123</p> <p>India - New Delhi Tel: 91-11-4160-8631 Fax: 91-11-4160-8632</p> <p>India - Pune Tel: 91-20-3019-1500</p> <p>Japan - Osaka Tel: 81-6-6152-7160 Fax: 81-6-6152-9310</p> <p>Japan - Tokyo Tel: 81-3-6880-3770 Fax: 81-3-6880-3771</p> <p>Korea - Daegu Tel: 82-53-744-4301 Fax: 82-53-744-4302</p> <p>Korea - Seoul Tel: 82-2-554-7200 Fax: 82-2-558-5932 or 82-2-558-5934</p> <p>Malaysia - Kuala Lumpur Tel: 60-3-6201-9857 Fax: 60-3-6201-9859</p> <p>Malaysia - Penang Tel: 60-4-227-8870 Fax: 60-4-227-4068</p> <p>Philippines - Manila Tel: 63-2-634-9065 Fax: 63-2-634-9069</p> <p>Singapore Tel: 65-6334-8870 Fax: 65-6334-8850</p> <p>Taiwan - Hsin Chu Tel: 886-3-5778-366 Fax: 886-3-5770-955</p> <p>Taiwan - Kaohsiung Tel: 886-7-213-7830</p> <p>Taiwan - Taipei Tel: 886-2-2508-8600 Fax: 886-2-2508-0102</p> <p>Thailand - Bangkok Tel: 66-2-694-1351 Fax: 66-2-694-1350</p>	<p>Austria - Wels Tel: 43-7242-2244-39 Fax: 43-7242-2244-393</p> <p>Denmark - Copenhagen Tel: 45-4450-2828 Fax: 45-4485-2829</p> <p>Finland - Espoo Tel: 358-9-4520-820</p> <p>France - Paris Tel: 33-1-69-53-63-20 Fax: 33-1-69-30-90-79</p> <p>France - Saint Cloud Tel: 33-1-30-60-70-00</p> <p>Germany - Garching Tel: 49-8931-9700</p> <p>Germany - Haan Tel: 49-2129-3766400</p> <p>Germany - Heilbronn Tel: 49-7131-67-3636</p> <p>Germany - Karlsruhe Tel: 49-721-625370</p> <p>Germany - Munich Tel: 49-89-627-144-0 Fax: 49-89-627-144-44</p> <p>Germany - Rosenheim Tel: 49-8031-354-560</p> <p>Israel - Ra'anana Tel: 972-9-744-7705</p> <p>Italy - Milan Tel: 39-0331-742611 Fax: 39-0331-466781</p> <p>Italy - Padova Tel: 39-049-7625286</p> <p>Netherlands - Druenen Tel: 31-416-690399 Fax: 31-416-690340</p> <p>Norway - Trondheim Tel: 47-7289-7561</p> <p>Poland - Warsaw Tel: 48-22-3325737</p> <p>Romania - Bucharest Tel: 40-21-407-87-50</p> <p>Spain - Madrid Tel: 34-91-708-08-90 Fax: 34-91-708-08-91</p> <p>Sweden - Gothenburg Tel: 46-31-704-60-40</p> <p>Sweden - Stockholm Tel: 46-8-5090-4654</p> <p>UK - Wokingham Tel: 44-118-921-5800 Fax: 44-118-921-5820</p>