

**Impact™  
Backplane  
Module Installation  
Press-In Tool**

**molex**

**Application Tooling  
Specification Sheet**

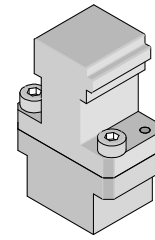

**Order No. 62201-8869**

## FEATURES

- Polarized tool prevents product damage
- Tool provides uniform distribution of press force across entire pin array
- May be used as a stand-alone tool or mounted in an optional holder with other Molex press-in tools

## SCOPE

Products: Impact™ Backplane Signal Module Assembly, 170335 Series, (4-Pair by 6 Column 85 Ohm Assemblies). See Product List below for specific part numbers.

## Product List

The following is a partial list of the product order numbers and their specifications this tool is designed to run. Updates to this list are available on [www.molex.com](http://www.molex.com).

170335 Series Numbers							
Guide Style	Columns	Assembly Order Number					
Unguided	6	170335-1303	170335-1304	170335-1305	170335-1306	170335-1307	170335-1308
		170335-1313	170335-1314	170335-1315	170335-1316	170335-1317	170335-1318
		170335-1323	170335-1324	170335-1325	170335-1326	170335-1327	170335-1328
		170335-1333	170335-1334	170335-1335	170335-1336	170335-1337	170335-1338
Left	6	170335-3303	170335-3304	170335-3305	170335-3306	170335-3307	170335-3308
		170335-3313	170335-3314	170335-3315	170335-3316	170335-3317	170335-3318
		170335-3323	170335-3324	170335-3325	170335-3326	170335-3327	170335-3328
		170335-3333	170335-3334	170335-3335	170335-3336	170335-3337	170335-3338
		170335-3343	170335-3344	170335-3345	170335-3346	170335-3347	170335-3348
		170335-3353	170335-3354	170335-3355	170335-3356	170335-3357	170335-3358
		170335-3363	170335-3364	170335-3365	170335-3366	170335-3367	170335-3368
		170335-3373	170335-3374	170335-3375	170335-3376	170335-3377	170335-3378
		170335-3383	170335-3384	170335-3385	170335-3386	170335-3387	170335-3388
		170335-7303	170335-7304	170335-7305	170335-7306	170335-7307	170335-7308
		170335-7313	170335-7314	170335-7315	170335-7316	170335-7317	170335-7318
		170335-7323	170335-7324	170335-7325	170335-7326	170335-7327	170335-7328
		170335-7333	170335-7334	170335-7335	170335-7336	170335-7337	170335-7338
		170335-7343	170335-7344	170335-7345	170335-7346	170335-7347	170335-7348
		170335-7353	170335-7354	170335-7355	170335-7356	170335-7357	170335-7358
		170335-7363	170335-7364	170335-7365	170335-7366	170335-7367	170335-7368
170335-7373	170335-7374	170335-7375	170335-7376	170335-7377	170335-7378		
170335-7383	170335-7384	170335-7385	170335-7386	170335-7387	170335-7388		
Right	6	170335-5303	170335-5304	170335-5305	170335-5306	170335-5307	170335-5308
		170335-5313	170335-5314	170335-5315	170335-5316	170335-5317	170335-5318
		170335-5323	170335-5324	170335-5325	170335-5326	170335-5327	170335-5328
		170335-5333	170335-5334	170335-5335	170335-5336	170335-5337	170335-5338

		170335 Series Numbers					
Guide Style	Columns	Assembly Order Number					
Right	6	170335-5343	170335-5344	170335-5345	170335-5346	170335-5347	170335-5348
		170335-5353	170335-5354	170335-5355	170335-5356	170335-5357	170335-5358
		170335-5363	170335-5364	170335-5365	170335-5366	170335-5367	170335-5368
		170335-5373	170335-5374	170335-5375	170335-5376	170335-5377	170335-5378
		170335-5383	170335-5384	170335-5385	170335-5386	170335-5387	170335-5388
		170335-9303	170335-9304	170335-9305	170335-9306	170335-9307	170335-9308
		170335-9313	170335-9314	170335-9315	170335-9316	170335-9317	170335-9318
		170335-9323	170335-9324	170335-9325	170335-9326	170335-9327	170335-9328
		170335-9333	170335-9334	170335-9335	170335-9336	170335-9337	170335-9338
		170335-9343	170335-9344	170335-9345	170335-9346	170335-9347	170335-9348
		170335-9353	170335-9354	170335-9355	170335-9356	170335-9357	170335-9358
		170335-9363	170335-9364	170335-9365	170335-9366	170335-9367	170335-9368
		170335-9373	170335-9374	170335-9375	170335-9376	170335-9377	170335-9378
		170335-9383	170335-9384	170335-9385	170335-9386	170335-9387	170335-9388

### Tool Setup

Depending on the number of connectors to be installed and/or the press used, this tool can be used alone or with a group of press-in tools, mounted in a 62201-95XX rail (ordered separately). See Figure 1.

### Tool Installation

The 62201-95XX rail is available in a variety of lengths to accommodate multiple press-in tools.

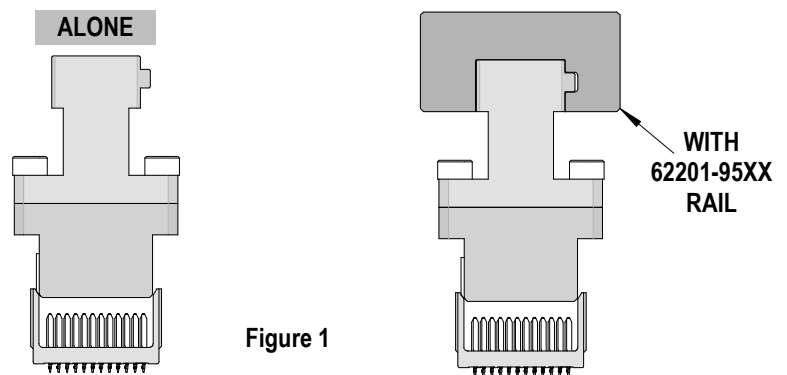

Figure 1

Rail Part Number	Rail Overall Length
62201-9501	24mm (0.94 in)
62201-9502	72mm (2.83 in)
62201-9503	156mm (6.14 in)
62201-9504	216mm (8.50 in)
62201-9509	254mm (10.0 in)
62201-9511	305mm (12.0 in)

Reference: This Press-In Tool is 11.25.1mm (.443 in.) long.

### Printed Circuit Board (PCB) Support

The Impact™ connectors require up to 3.6kg (8 lb) of force per pin to press into the PCB. To prevent excessive PCB flexure and/or damage to the PCB, a support plate is strongly recommended directly beneath the connector hole pattern.

Due to the custom nature of every application, Molex does not offer any PCB support plate. The customer must furnish their own support plate.

When creating the PCB support plate, remember to allow clearance for the connector pins as they pass through the PCB thickness.

## Press Equipment Recommendations

Many types of presses can be used to install Impact™ connectors, but to assure consistent connector installation Molex recommends the following press criteria:

1. The capability to detect force variations as low as 4.5kg (10 lb) during the press-in cycle; excessive force measurements should stop the press-in cycle.
2. The rate of pressing can be regulated as low as 0.13mm (0.005 in) per second.
3. Press stroke control to within 0.25mm (0.010 in).
4. Total press stroke must be at least 19mm (0.75 in).
5. For statistical purposes, automatic collection of force and distance data.

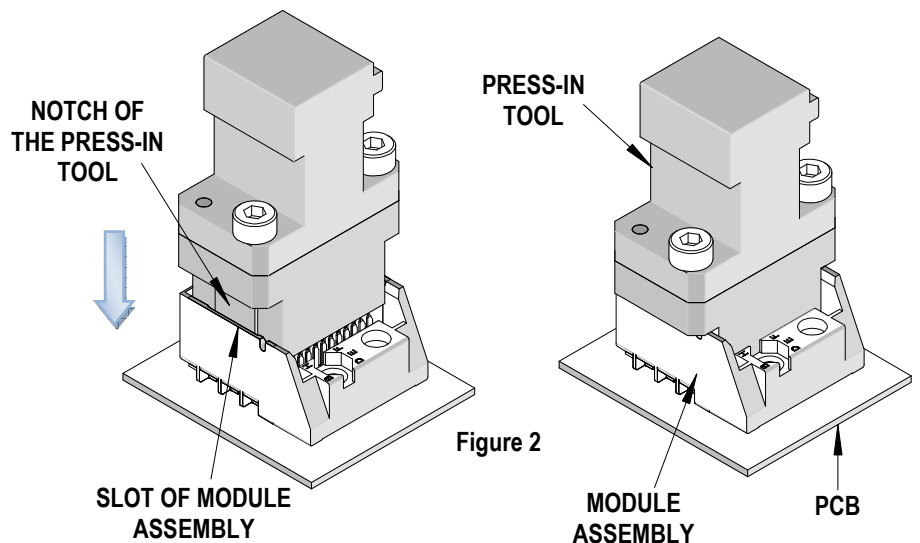

Figure 2

## Tool Operation

1. Insert by hand the backplane signal module assembly (s) carefully into the PCB hole pattern. Make sure the connector(s) are oriented properly by confirming the location of the #1 circuit notch with respect to the PCB layout.
2. Insert the Press-In Tool making sure that the notch in this tool is inserted into the slot on top of the connector housing of the backplane signal module assembly. See Figure 2.
3. Using the application tool and an appropriate press, seat the header assembly until there is less than 0.10mm (.004 in) clearance between the bottom of the plastic housing and the surface of the PCB. See Figure 3.

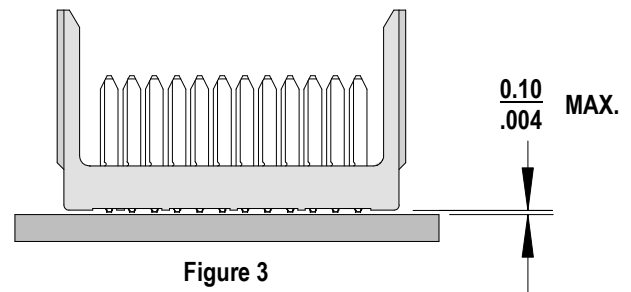

Figure 3

There should be no broken stand-offs along the perimeter of the part (an indication of over-pressing).

**CAUTION:** To prevent injury, never operate any press without the guards in place. Refer to the press manufacturer's instruction manual.

**CAUTION:** Molex application tooling specifications are valid only when used with Molex connectors and tooling.

## Contact Information

For more information on Molex application tooling please contact Molex at 1-800-786-6539.

Visit our Web site at <http://www.molex.com>