

THIS DRAWING IS UNPUBLISHED. RELEASED FOR PUBLICATION
 © COPYRIGHT - By - ALL RIGHTS RESERVED.

LOC	DIST	REVISIONS					
G	14	P	LTR	DESCRIPTION	DATE	DWN	APVD
			H2	REVISED PER ECO-11-005027	12MAR11	RK	HMR

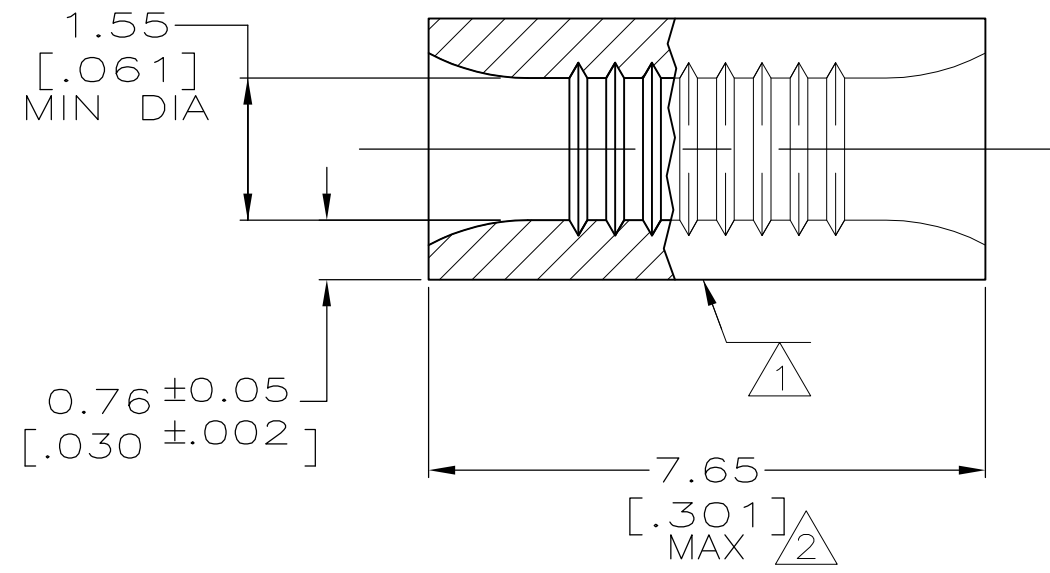
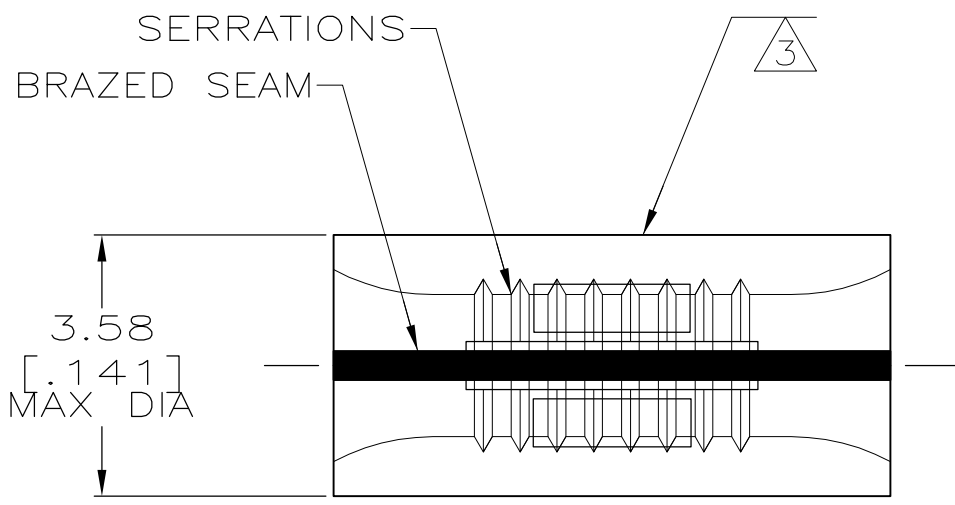

AMP WIRE RANGE	E13288 Listed
22-16 AWG SOLID OR STRANDED	NOT APPLICABLE
LR7189 Certified	MILITARY P/N AND CLASS
NOT APPLICABLE	NOT APPLICABLE

- ① STAMP AMP 22-18 APPROX AS SHOWN
22-16 SPLICES ARE STAMPED WITH 22-18 IN
ACCORDANCE WITH MILITARY SPEC MIL-T-7928
COMMERCIAL WIRE RANGE IS 22-16
- ② MAXIMUM LENGTH DOES NOT INCLUDE
MANUFACTURING TABS
- ③ WIRE BARREL COLOR CODED ORANGE
TO DENOTE NICKEL MATERIAL

NONE	322326-1
REQD	322326
③ COLOR CODING	PART NUMBER

AMP INCORPORATED
CUSTOMER SERVICE SYSTEMS

FOR ADDITIONAL PRODUCT INFORMATION OR COPIES OF DRAWINGS AND TECHNICAL DOCUMENTS	PRODUCT INFORMATION CENTER 1-800-522-6752	RECOMMENDED OPERATING TEMPERATURE: 649° C MAX
FOR APPLICATION TOOLING INFORMATION	TOOLING ASSISTANCE CENTER 1-800-722-1111	VOLTAGE RATING: NOT APPLICABLE
FOR ORDER ENTRY	1-800-526-5142	WIRE CROSS SECTIONAL AREA RANGE: 0.26-1.65mm ² [509-3,250] CIR MILS SOLID OR STRANDED

THIS DRAWING IS A CONTROLLED DOCUMENT.

DIMENSIONS:	TOLERANCES UNLESS OTHERWISE SPECIFIED:
mm [INCHES]	
	0 PLC ± -
	1 PLC ± -
	2 PLC ± -
	3 PLC ± -
	4 PLC ± -
	ANGLES ± -
MATERIAL	FINISH
NICKEL PER ASTM B-162 ANNEALED	-

DWN DK SCHRUM 14NOV96	TE Connectivity
CHK MJ SPICER 19NOV96	
APVD JL MECKLEY 19NOV96	
PRODUCT SPEC	
APPLICATION SPEC	NAME SPLICE, PARALLEL, HIGH TEMPERATURE, STRATO - THERM™
WEIGHT -	SIZE A3 CAGE CODE 00779 DRAWING NO C-322326 RESTRICTED TO -
CUSTOMER DRAWING	SCALE 10:1 SHEET 1 OF 1 REV H2