



IA186EB/IA188EB
8-Bit/16-Bit Microcontrollers

Data Sheet

Copyright © 2011 by Innovasic Semiconductor, Inc.

Published by Innovasic Semiconductor, Inc.
3737 Princeton Drive NE, Suite 130, Albuquerque, NM 87107

MILES™ is a trademark Innovasic Semiconductor, Inc.
Intel® is a registered trademark of Intel Corporation

TABLE OF CONTENTS

1.	Introduction.....	7
1.1	General Description.....	7
1.2	Features	8
2.	Packaging, Pin Descriptions, and Physical Dimensions.....	9
2.1	Packages and Pinouts	9
2.1.1	IA186EB 84 PLCC Package.....	10
2.1.2	IA188EB 84 PLCC Package.....	12
2.1.3	PLCC Physical Dimensions.....	14
2.1.4	IA186EB 80 PQFP Package	15
2.1.5	IA188EB 80 PQFP Package	17
2.1.6	PQFP Physical Dimensions	19
2.1.7	IA186EB 80 LQFP Package	20
2.1.8	IA188EB 80 LQFP Package	22
2.1.9	LQFP Physical Dimensions.....	24
2.2	IA186EB Pin/Signal Descriptions.....	25
2.3	IA188EB Pin/Signal Descriptions.....	34
3.	Maximum Ratings, Thermal Characteristics, and DC Parameters	42
4.	Functional Description.....	44
4.1	Device Architecture.....	44
4.1.1	Bus Interface Unit.....	44
4.1.2	Clock Generator.....	46
4.1.3	Interrupt Control Unit	47
4.1.4	Timer/Counter Unit	47
4.1.5	Serial Communications Unit.....	47
4.1.6	Chip-Select Unit	47
4.1.7	I/O Port Unit	48
4.1.8	Refresh Control Unit.....	48
4.1.9	Power Management Unit	48
4.2	Peripheral Architecture	48
4.3	Reference Documents	51
5.	AC Specifications	51
5.1	AC Test Conditions	55
5.2	Clock Input and Clock Output Timing Characteristics	56
5.3	Serial Port Mode 0 Timing Characteristics	58
6.	Reset Operation	59
7.	Bus Timing	59
8.	Instruction Execution Times.....	69
9.	Errata.....	77
9.1	Summary	77
9.2	Detail	78

10. Revision History83
11. For Additional Information.....85

LIST OF FIGURES

Figure 1. IA186EB 84-Pin PLCC Package Diagram.....	10
Figure 2. IA188EB 84-Pin PLCC Package Diagram.....	12
Figure 3. 84-Pin PLCC Physical Package Dimensions	14
Figure 4. IA186EB 80-Pin PQFP Package Diagram	15
Figure 5. IA188EB 80-Pin PQFP Package Diagram	17
Figure 6. 80-Pin PQFP Physical Package Dimensions	19
Figure 7. IA186EB 80-Pin LQFP Package Diagram	20
Figure 8. IA188EB 80-Pin LQFP Package Diagram	22
Figure 9. 80-Pin LQFP Physical Package Dimensions.....	24
Figure 10. IA186EB/IA188EB Functional Block Diagram.....	45
Figure 11. Clock Circuit Connection Options	46
Figure 12. AC Input Characteristics	51
Figure 13. AC Output Characteristics.....	52
Figure 14. Relative Timing Characteristics	54
Figure 15. AC Test Load	55
Figure 16. Clock Input and Clock Output Timing Characteristics	56
Figure 17. Serial Port Mode 0 Timing Characteristics	58
Figure 18. Cold Reset Timing.....	60
Figure 19. Warm Reset Timing	61
Figure 20. Read, Fetch, and Refresh Cycle Timing.....	62
Figure 21. Write Cycle Timing.....	63
Figure 22. Halt Cycle Timing	64
Figure 23. Interrupt Acknowledge (inta1_n, inta0_n) Cycle Timing	65
Figure 24. hold/hlda Timing	66
Figure 25. Refresh During Hold Acknowledge Timing	67
Figure 26. Ready Timing	68

LIST OF TABLES

Table 1. IA186EB 84-Pin PLCC Pin Listing.....	11
Table 2. IA188EB 84-Pin PLCC Pin Listing.....	13
Table 3. IA186EB 80-Pin PQFP Pin Listing.....	16
Table 4. IA188EB 80-Pin PQFP Pin Listing.....	18
Table 5. IA186EB 80-Pin LQFP Pin Listing.....	21
Table 6. IA188EB 80-Pin LQFP Pin Listing.....	23
Table 7. IA186EB Pin/Signal Descriptions.....	25
Table 8. IA188EB Pin/Signal Descriptions.....	34
Table 9. IA186EB and IA188EB Absolute Maximum Ratings.....	42
Table 10. IA186EB and IA188EB Thermal Characteristics.....	42
Table 11. IA186EB and IA188EB DC Parameters.....	43
Table 12. Peripheral Control Block Registers.....	49
Table 13. AC Input Characteristics for 5.0-Volt Operation.....	52
Table 14. AC Input Characteristics for 3.3-Volt Operation.....	52
Table 15. AC Output Characteristics for 5.0-Volt Operation.....	53
Table 16. AC Output Characteristics for 3.3-Volt Operation.....	53
Table 17. Relative Timing Characteristics.....	55
Table 18. Clock Input and Clock Output Timing Characteristics for 5.0-Volt Operation.....	56
Table 19. Clock Input and Output Characteristics for 3.3-Volt Operation.....	57
Table 20. Serial Port Mode 0 Timing Characteristics.....	58
Table 21. Instruction Set Timing.....	69
Table 22. Innovasic Part Number Cross-Reference for the PLCC.....	74
Table 23. Innovasic Part Number Cross-Reference for the PQFP.....	75
Table 24. Innovasic Part Number Cross-Reference for the LQFP.....	76
Table 25. Summary of Errata.....	77
Table 26. Revision History.....	83

1. Introduction

The Innovasic Semiconductor IA186EB and IA188EB microcontrollers are form, fit, and function replacements for the original Intel® 80C186EB, 80C188EB, 80L186EB, and 80L188EB 16-bit high-integration embedded processors.

These devices are produced using Innovasic's Managed IC Lifetime Extension System (MILESTM). This cloning technology, which produces replacement ICs beyond simple emulations, ensures complete compatibility with the original device, including any "undocumented features." Additionally, the MILES process captures the clone design in such a way that production of the clone can continue even as silicon technology advances.

The IA186EB and IA188EB microcontrollers replace the obsolete Intel 80C186EB and 80C188EB devices, allowing users to retain existing board designs, software compilers/assemblers, and emulation tools, thereby avoiding expensive redesign efforts.

1.1 General Description

The Innovasic Semiconductor IA186EB and IA188EB microcontrollers are an upgrade for the 80C186EB/80C188EB microcontroller designs with integrated peripherals to provide increased functionality and reduce system costs. The IA186EB and IA188EB devices are designed to satisfy requirements of embedded products designed for telecommunications, office automation and storage, and industrial controls.

The IA186EB and IA188EB microcontrollers have a set of base peripherals beneficial to many embedded applications and include a standard numeric interface, an interrupt control unit, a chip-select unit, a DRAM refresh control unit, a power management unit, and three 16-bit timer/counters.

The IA186EB and IA188EB microcontrollers are capable of operating at 5.0 or 3.3 volts. This datasheet discusses both modes of operation. Where applicable, characteristics specific to either 3.3 or 5.0 volt operation are identified separately throughout this datasheet.

Additionally, the IA186EB and IA188EB include two integrated serial ports that support both synchronous and asynchronous communications, simplifying inter-processor and display communications. The IA186EB and IA188EB also have an enhanced chip-select unit and two multiplexed I/O ports. The enhanced chip-select unit offers 10 general chip selects, each with the ability to address up to 1 Mbyte. This enhanced unit enables memory-bank switching to expand the IA186EB/IA188EB 1 Mbyte address space. The I/O ports allow for basic functions such as scanning keypads for input. The ports can also be used to control system power consumption, disabling unneeded components.

The serial ports, I/O capabilities, and enhanced chip selects make the IA186EB/IA188EB an excellent processor for portable data acquisition or communication applications.

1.2 Features

The primary features of the IA186EB and IA188EB microcontrollers are as follows:

- Low-Power Operating Modes
 - Idle (freezes CPU clocks; peripherals are kept active)
 - Power-Down (freezes all internal clocks)
- Low-Power CPU Core (static)
- Direct Addressing Capability
 - Memory: 1 Mbyte
 - I/O: 64 Kbyte
- I/O Ports
 - 2 each, 8-Bit
 - Multiplexed
- Clock Generator
- Chip Selects
 - 10 each, Programmable
 - Integral Wait-State Generator
- Memory Refresh Control Unit
- Interrupt Controller, Programmable
- Counter/Timers
 - 3 each, 16-Bit
 - Programmable
- Serial Channels
 - 2 each, UARTs
 - Integral Baud Rate Generator
- Operating Frequency (system clock input)
 - 50 MHz @ 5V
 - 32 MHz @ 3.3V

[Chapter 4, Functional Description](#), provides details of the IA186EB and IA188EB microcontrollers, including the features listed above.

2. Packaging, Pin Descriptions, and Physical Dimensions

Information on the packages and pin descriptions for the IA186EB and the IA188EB is provided separately. Refer to sections, figures, and tables for information on the device of interest.

2.1 Packages and Pinouts

The Innovasic Semiconductor IA186EB and IA188EB microcontroller is available in the following packages:

- 84-Pin Plastic Leaded Chip Carrier (PLCC), equivalent to original PLCC package
- 80-Pin Plastic Quad Flat Pack (PQFP), equivalent to original PQFP package
- 80-Pin Low-Profile Quad Flat Pack (LQFP), equivalent to original SQFP package

2.1.1 IA186EB 84 PLCC Package

The pinout for the IA186EB 84 PLCC Package is as shown in Figure 1. The corresponding pinout is provided in Table 1.

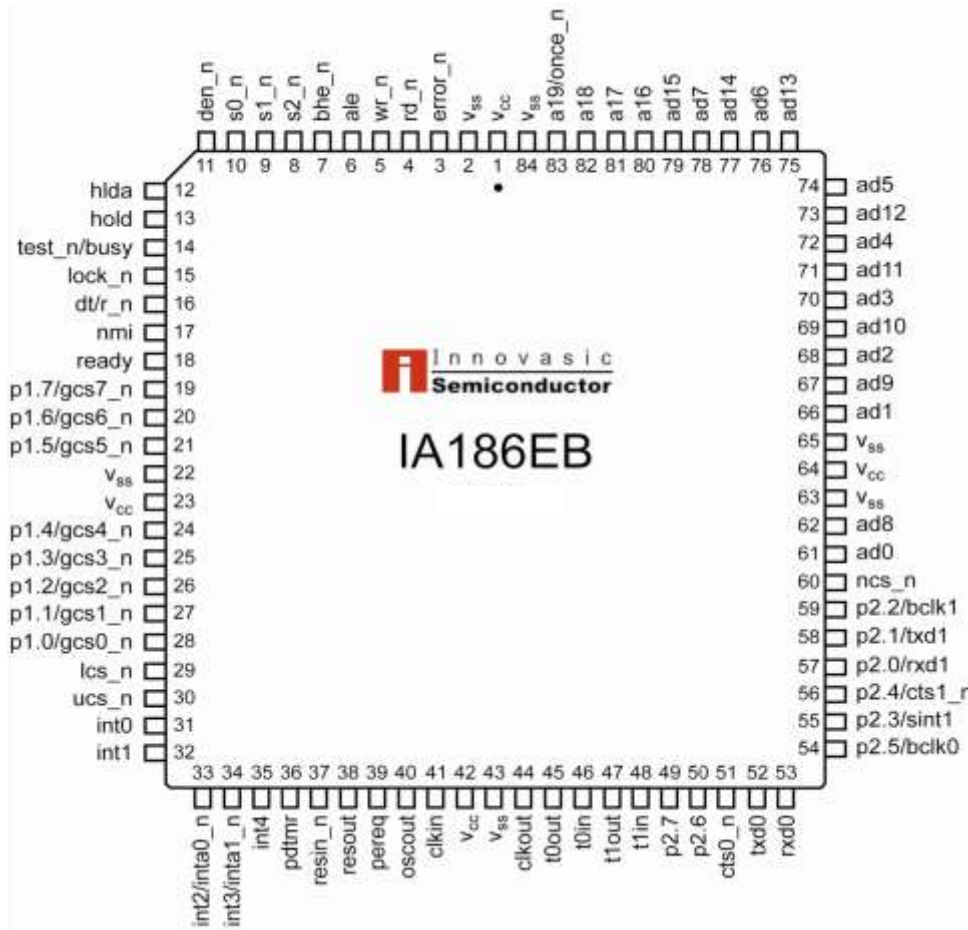

Figure 1. IA186EB 84-Pin PLCC Package Diagram

Table 1. IA186EB 84-Pin PLCC Pin Listing

Pin	Name	Pin	Name	Pin	Name	Pin	Name
1	V _{cc}	22	V _{ss}	43	V _{ss}	64	V _{cc}
2	V _{ss}	23	V _{cc}	44	clkout	65	V _{ss}
3	error_n	24	p1.4/gcs4_n	45	t0out	66	ad1
4	rd_n	25	p1.3/gcs3_n	46	t0in	67	ad9
5	wr_n	26	p1.2/gcs2_n	47	t1out	68	ad2
6	ale	27	p1.1/gcs1_n	48	t1in	69	ad10
7	bhe_n	28	p1.0/gcs0_n	49	p2.7	70	ad3
8	s2_n	29	lcs_n	50	p2.6	71	ad11
9	s1_n	30	ucs_n	51	cts0_n	72	ad4
10	s0_n	31	int0	52	txd0	73	ad12
11	den_n	32	int1	53	rxd0	74	ad5
12	hlida	33	int2/inta0_n	54	p2.5/bclk0	75	ad13
13	hold	34	int3/inta1_n	55	p2.3/sint1	76	ad6
14	test_n/busy	35	int4	56	p2.4/cts1_n	77	ad14
15	lock_n	36	pdtmr	57	p2.0/rxd1	78	ad7
16	dt/r_n	37	resin_n	58	p2.1/txd1	79	ad15
17	nmi	38	resout	59	p2.2/bclk1	80	a16
18	ready	39	pereq	60	ncs_n	81	a17
19	p1.7/gcs7_n	40	oscout	61	ad0	82	a18
20	p1.6/gcs6_n	41	clkin	62	ad8	83	a19/once_n
21	p1.5/gcs5_n	42	V _{cc}	63	V _{ss}	84	V _{ss}

2.1.2 IA188EB 84 PLCC Package

The pinout for the IA188EB 84 PLCC Package is as shown in Figure 2. The corresponding pinout is provided in Table 2.

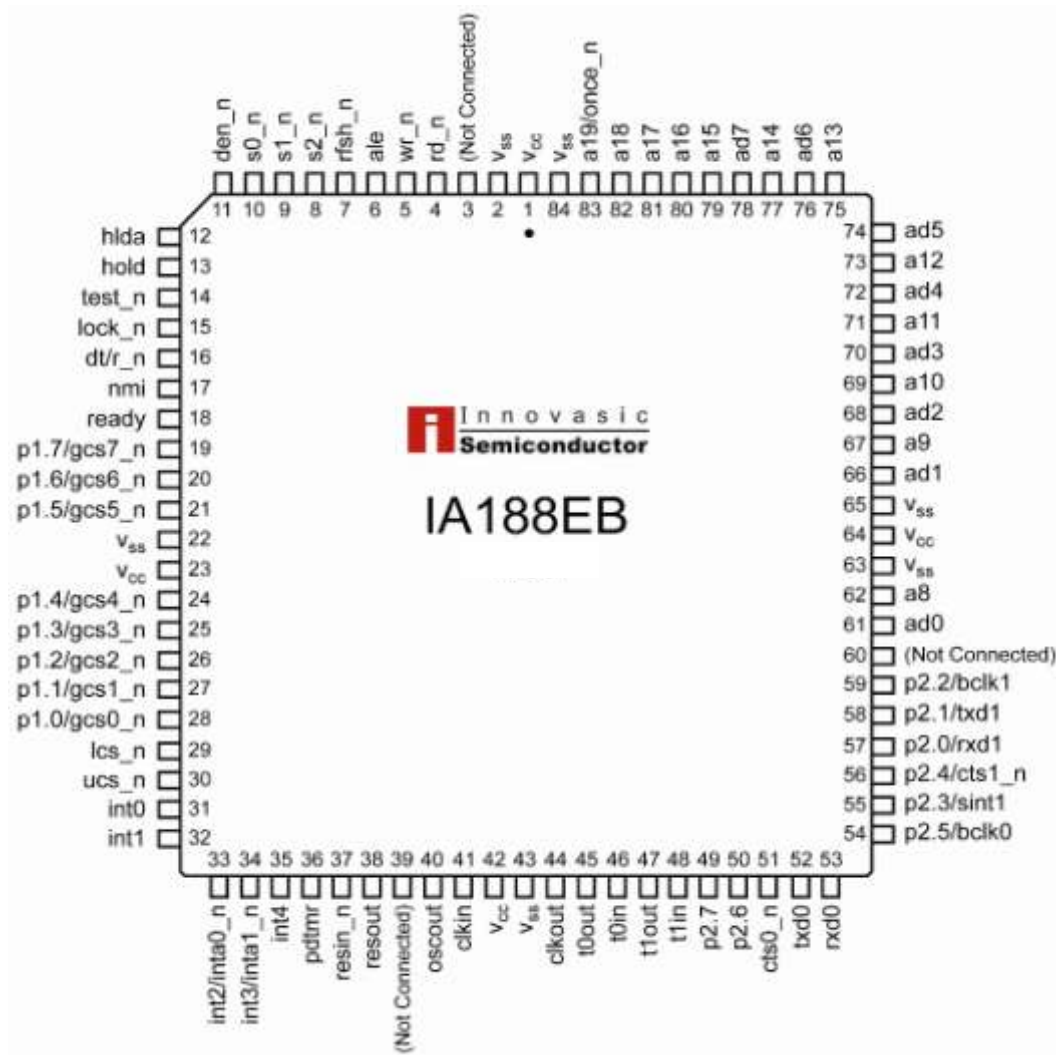

Figure 2. IA188EB 84-Pin PLCC Package Diagram

Table 2. IA188EB 84-Pin PLCC Pin Listing

Pin	Name	Pin	Name	Pin	Name	Pin	Name
1	V _{cc}	22	V _{ss}	43	V _{ss}	64	V _{cc}
2	V _{ss}	23	V _{cc}	44	clkout	65	V _{ss}
3	Not Connected	24	p1.4/gcs4_n	45	t0out	66	ad1
4	rd_n	25	p1.3/gcs3_n	46	t0in	67	a9
5	wr_n	26	p1.2/gcs2_n	47	t1out	68	ad2
6	ale	27	p1.1/gcs1_n	48	t1in	69	a10
7	rfsh_n	28	p1.0/gcs0_n	49	p2.7	70	ad3
8	s2_n	29	lcs_n	50	p2.6	71	a11
9	s1_n	30	ucs_n	51	cts0_n	72	ad4
10	s0_n	31	int0	52	txd0	73	a12
11	den_n	32	int1	53	rxd0	74	ad5
12	hlda	33	int2/inta0_n	54	p2.5/bclk0	75	a13
13	hold	34	int3/inta1_n	55	p2.3/sint1	76	ad6
14	test_n	35	int4	56	p2.4/cts1_n	77	a14
15	lock_n	36	pdtrmr	57	p2.0/rxd1	78	ad7
16	dt/r_n	37	resin_n	58	p2.1/txd1	79	a15
17	nmi	38	resout	59	p2.2/bclk1	80	a16
18	ready	39	Not Connected	60	Not Connected	81	a17
19	p1.7/gcs7_n	40	oscout	61	ad0	82	a18
20	p1.6/gcs6_n	41	clkin	62	a8	83	a19/once_n
21	p1.5/gcs5_n	42	V _{cc}	63	V _{ss}	84	V _{ss}

2.1.3 PLCC Physical Dimensions

The physical dimensions for the 84 PLCC are as shown in Figure 3.

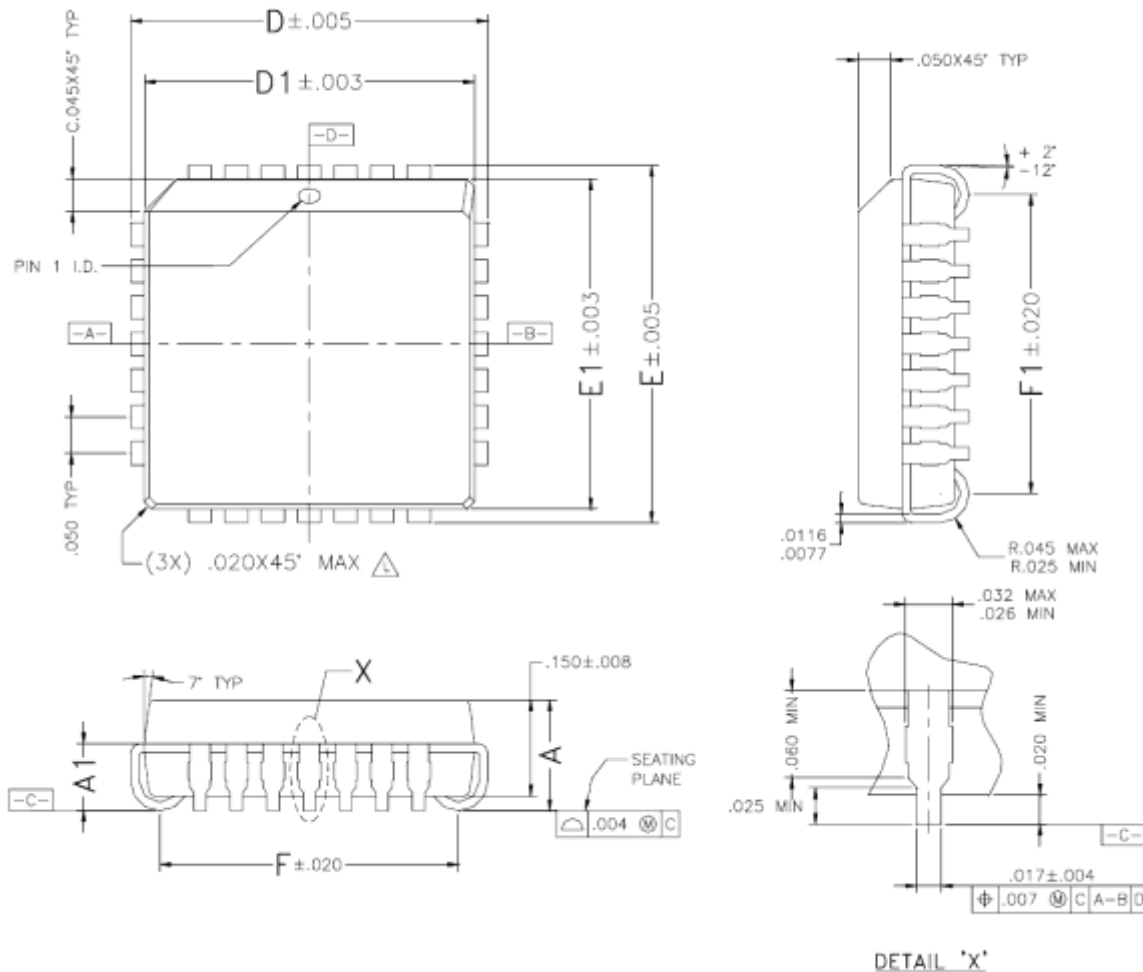

Note: The bottom package is bigger than the top package by 0.004 inches (0.002 inches per side). Bottom package dimensions follow those stated in this drawing.

Figure 3. 84-Pin PLCC Physical Package Dimensions

2.1.4 IA186EB 80 PQFP Package

The pinout for the IA186EB 80 PQFP Package is as shown in Figure 4. The corresponding pinout is provided in Table 3.

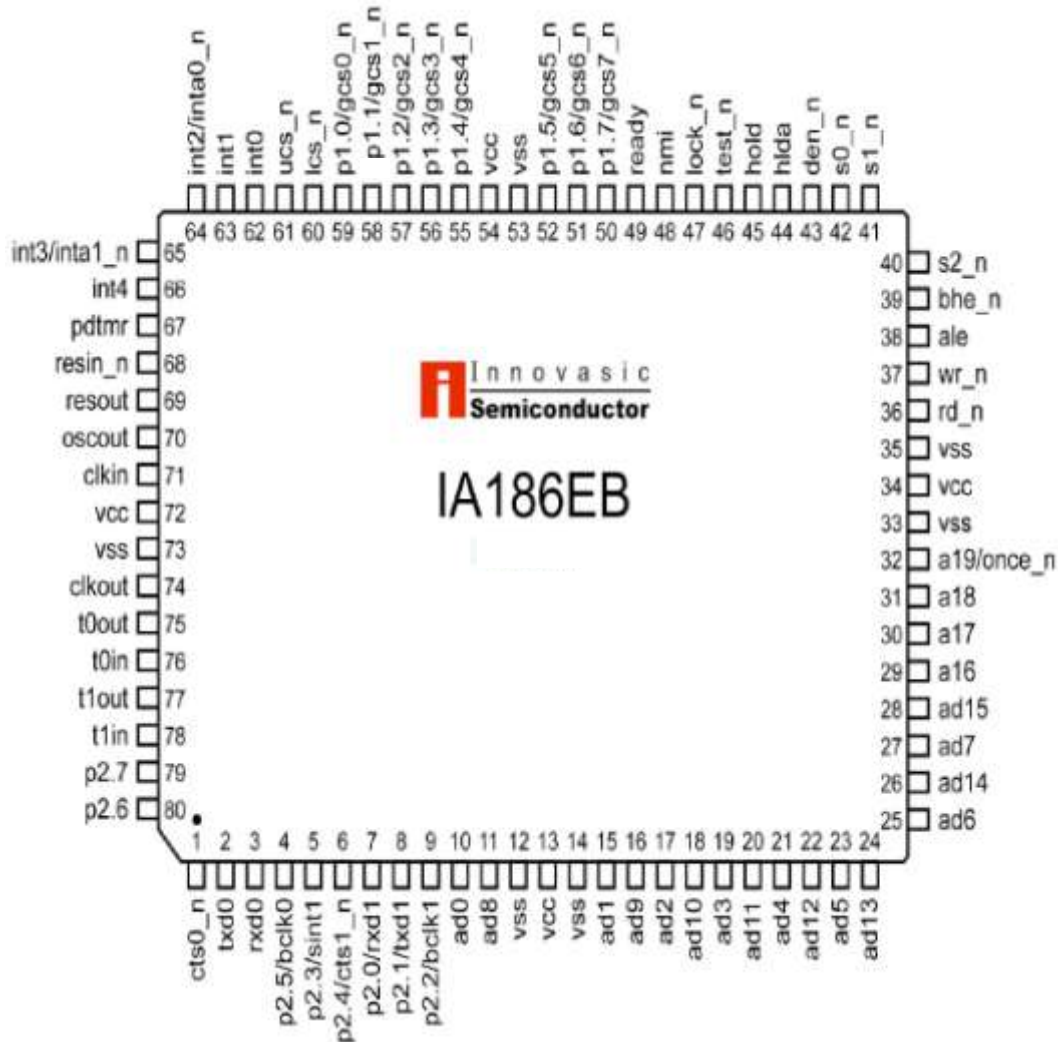

Figure 4. IA186EB 80-Pin PQFP Package Diagram

Table 3. IA186EB 80-Pin PQFP Pin Listing

Pin	Name	Pin	Name	Pin	Name	Pin	Name
1	cts0_n	21	ad4	41	s1_n	61	ucs_n
2	txd0	22	ad12	42	s0_n	62	int0
3	rxd0	23	ad5	43	den_n	63	int1
4	p2.5/bclk0	24	ad13	44	hlda	64	int2/inta0_n
5	p2.3/sint1	25	ad6	45	hold	65	int3/inta1_n
6	p2.4/cts1_n	26	ad14	46	test_n	66	int4
7	p2.0/rxd1	27	ad7	47	lock_n	67	pdtmr
8	p2.1/txd1	28	ad15	48	nmi	68	resin_n
9	p2.2/bclk1	29	a16	49	ready	69	resout
10	ad0	30	a17	50	p1.7/gcs7_n	70	oscout
11	ad8	31	a18	51	p1.6/gcs6_n	71	clkln
12	Vss	32	a19/once_n	52	p1.5/gcs5_n	72	Vcc
13	Vcc	33	Vss	53	Vss	73	Vss
14	Vss	34	Vcc	54	Vcc	74	clkout
15	ad1	35	Vss	55	p1.4/gcs4_n	75	t0out
16	ad9	36	rd_n	56	p1.3/gcs3_n	76	t0in
17	ad2	37	wr_n	57	p1.2/gcs2_n	77	t1out
18	ad10	38	ale	58	p1.1/gcs1_n	78	t1in
19	ad3	39	bhe_n	59	p1.0/gcs0_n	79	p2.7
20	ad11	40	s2_n	60	lcs_n	80	p2.6

2.1.5 IA188EB 80 PQFP Package

The pinout for the IA188EB 80 PQFP Package is as shown in Figure 5. The corresponding pinout is provided in Table 4.

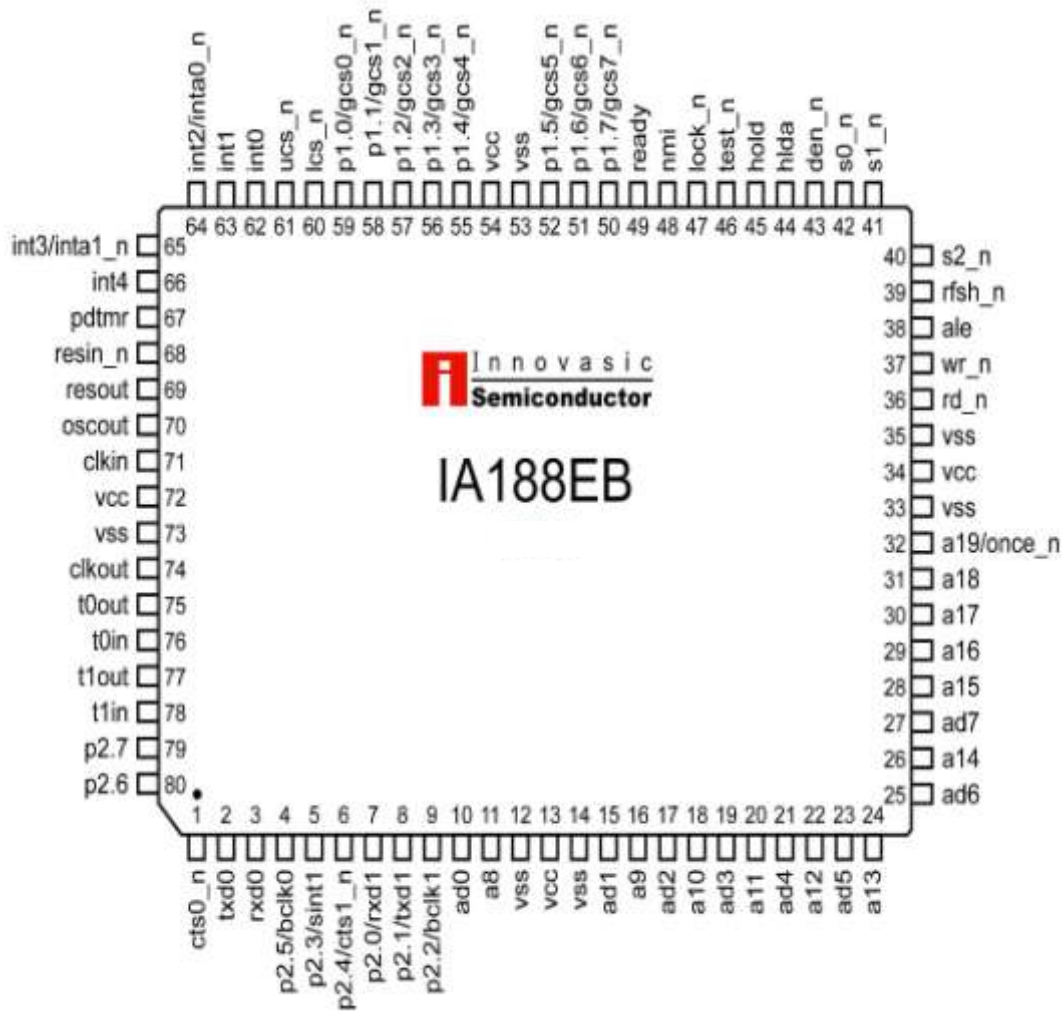

Figure 5. IA188EB 80-Pin PQFP Package Diagram

Table 4. IA188EB 80-Pin PQFP Pin Listing

Pin	Name	Pin	Name	Pin	Name	Pin	Name
1	cts0_n	21	ad4	41	s1_n	61	ucs_n
2	txd0	22	a12	42	s0_n	62	int0
3	rxd0	23	ad5	43	den_n	63	int1
4	p2.5/bclk0	24	a13	44	hlda	64	int2/inta0_n
5	p2.3/sint1	25	ad6	45	hold	65	int3/inta1_n
6	p2.4/cts1_n	26	a14	46	test_n	66	int4
7	p2.0/rxd1	27	ad7	47	lock_n	67	pdtmr
8	p2.1/txd1	28	a15	48	nmi	68	resin_n
9	p2.2/bclk1	29	a16	49	ready	69	resout
10	ad0	30	a17	50	p1.7/gcs7_n	70	oscout
11	a8	31	a18	51	p1.6/gcs6_n	71	clkln
12	Vss	32	a19/once_n	52	p1.5/gcs5_n	72	Vcc
13	Vcc	33	Vss	53	Vss	73	Vss
14	Vss	34	Vcc	54	Vcc	74	clkout
15	ad1	35	Vss	55	p1.4/gcs4_n	75	t0out
16	a9	36	rd_n	56	p1.3/gcs3_n	76	t0in
17	ad2	37	wr_n	57	p1.2/gcs2_n	77	t1out
18	a10	38	ale	58	p1.1/gcs1_n	78	t1in
19	ad3	39	rfsn_n	59	p1.0/gcs0_n	79	p2.7
20	a11	40	s2_n	60	lcs_n	80	p2.6

2.1.7 IA186EB 80 LQFP Package

The pinout for the IA186EB 80 LQFP Package is as shown in Figure 7. The corresponding pinout is provided in Table 5.

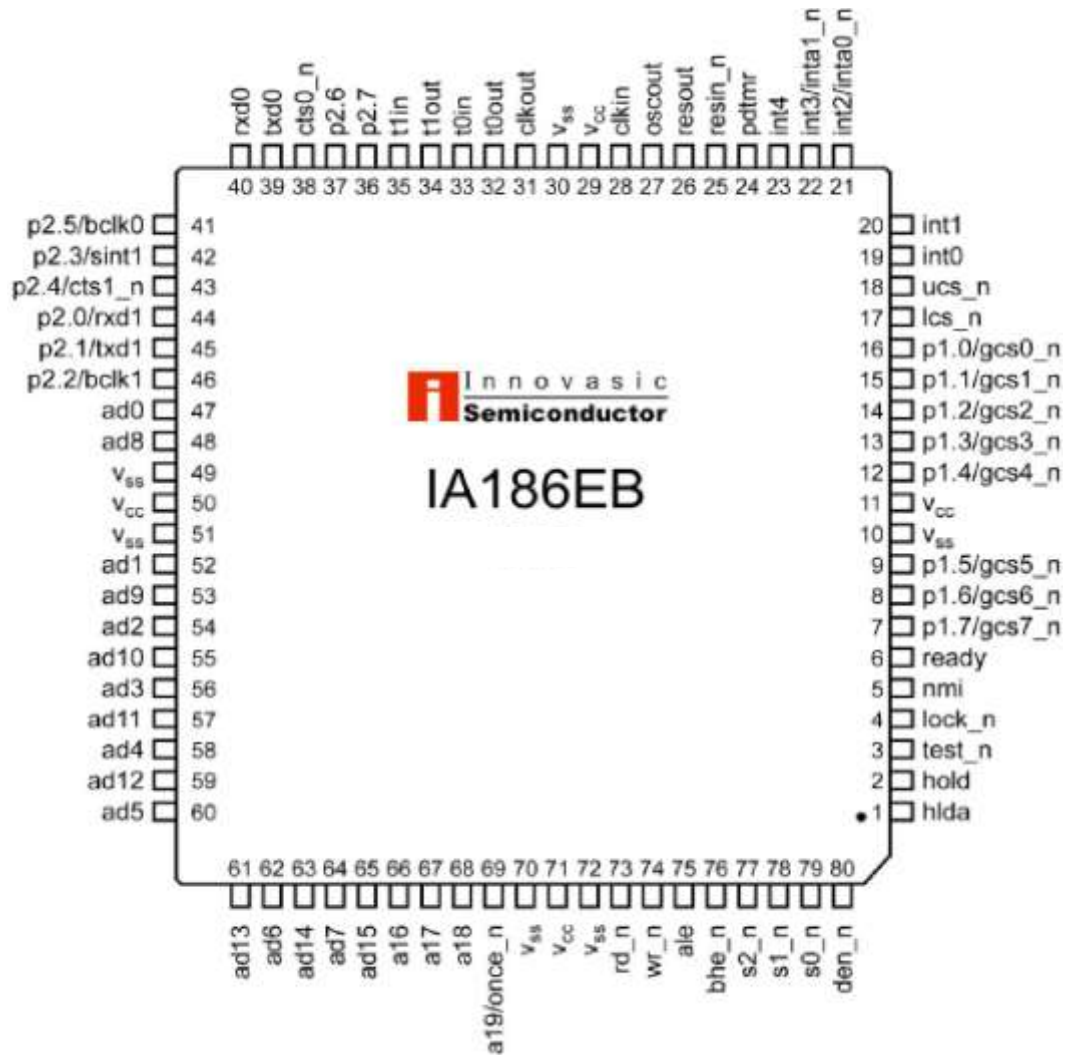

Figure 7. IA186EB 80-Pin LQFP Package Diagram

Table 5. IA186EB 80-Pin LQFP Pin Listing

Pin	Name	Pin	Name	Pin	Name	Pin	Name
1	hlda	21	int2/inta0_n	41	p2.5/bclk0	61	ad13
2	hold	22	int3/inta1_n	42	p2.3/sint1	62	ad6
3	test_n	23	int4	43	p2.4/cts1_n	63	ad14
4	lock_n	24	pdtmr	44	p2.0/rxd1	64	ad7
5	nmi	25	resin_n	45	p2.1/txd1	65	ad15
6	ready	26	resout	46	p2.2/bclk1	66	a16
7	p1.7/gcs7_n	27	oscout	47	ad0	67	a17
8	p1.6/gcs6_n	28	clkin	48	ad8	68	a18
9	p1.5/gcs5_n	29	V _{cc}	49	V _{ss}	69	a19/once_n
10	V _{ss}	30	V _{ss}	50	V _{cc}	70	V _{ss}
11	V _{cc}	31	clkout	51	V _{ss}	71	V _{cc}
12	p1.4/gcs4_n	32	t0out	52	ad1	72	V _{ss}
13	p1.3/gcs3_n	33	t0in	53	ad9	73	rd_n
14	p1.2/gcs2_n	34	t1out	54	ad2	74	wr_n
15	p1.1/gcs1_n	35	t1in	55	ad10	75	ale
16	p1.0/gcs0_n	36	p2.7	56	ad3	76	bhe_n
17	lcs_n	37	p2.6	57	ad11	77	s2_n
18	ucs_n	38	cts0_n	58	ad4	78	s1_n
19	int0	39	txd0	59	ad12	79	s0_n
20	int1	40	rxid0	60	ad5	80	den_n

2.1.8 IA188EB 80 LQFP Package

The pinout for the IA188EB 80 LQFP Package is as shown in Figure 8. The corresponding pinout is provided in Table 6.

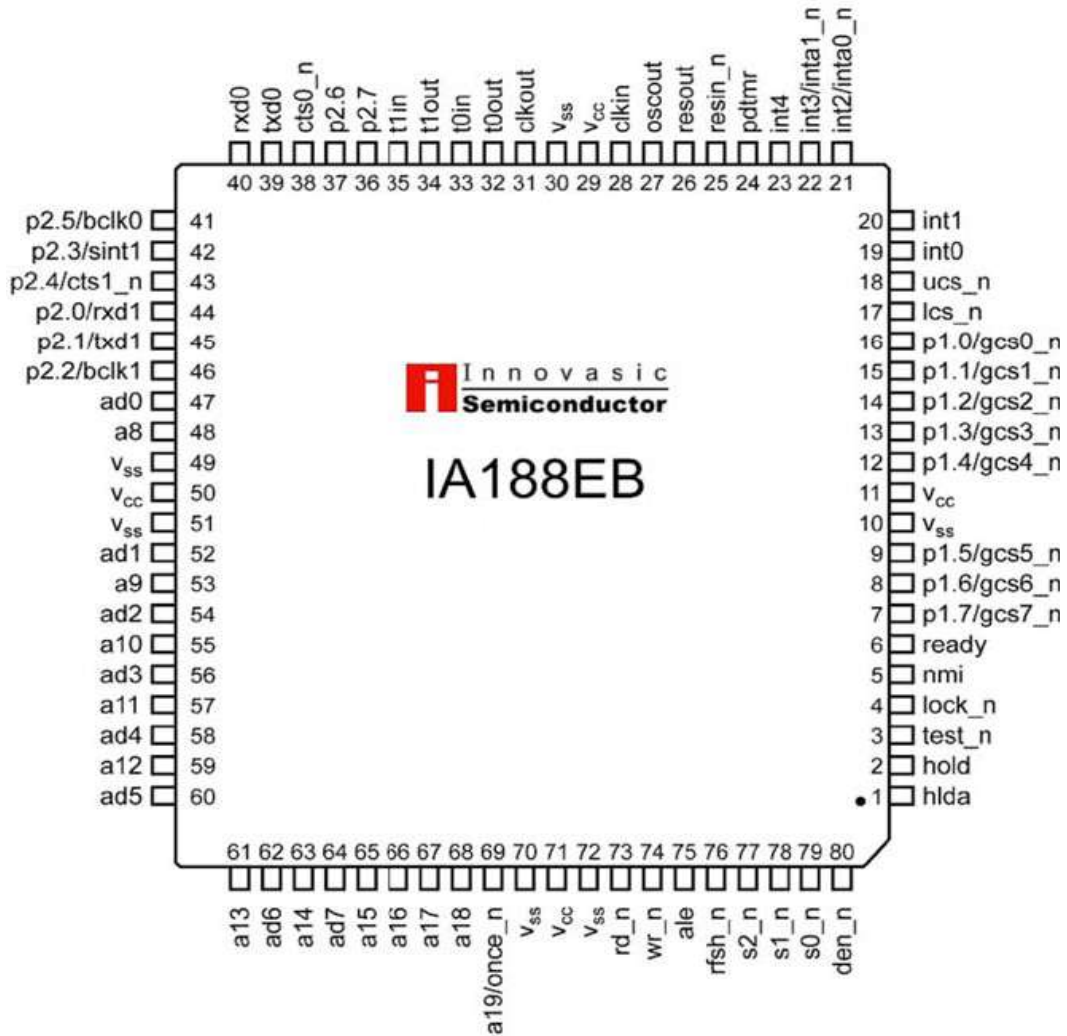

Figure 8. IA188EB 80-Pin LQFP Package Diagram

Table 6. IA188EB 80-Pin LQFP Pin Listing

Pin	Name	Pin	Name	Pin	Name	Pin	Name
1	hlda	21	int2/inta0_n	41	p2.5/bclk0	61	a13
2	hold	22	int3/inta1_n	42	p2.3/sint1	62	ad6
3	test_n	23	int4	43	p2.4/cts1_n	63	a14
4	lock_n	24	pdtmr	44	p2.0/rxd1	64	ad7
5	nmi	25	resin_n	45	p2.1/txd1	65	a15
6	ready	26	resout	46	p2.2/bclk1	66	a16
7	p1.7/gcs7_n	27	oscout	47	ad0	67	a17
8	p1.6/gcs6_n	28	clkin	48	a8	68	a18
9	p1.5/gcs5_n	29	V _{cc}	49	V _{ss}	69	a19/once_n
10	V _{ss}	30	V _{ss}	50	V _{cc}	70	V _{ss}
11	V _{cc}	31	clkout	51	V _{ss}	71	V _{cc}
12	p1.4/gcs4_n	32	t0out	52	ad1_n	72	V _{ss}
13	p1.3/gcs3_n	33	t0in	53	a9	73	rd_n
14	p1.2/gcs2_n	34	t1out	54	ad2	74	wr_n
15	p1.1/gcs1_n	35	t1in	55	a10	75	ale
16	p1.0/gcs0_n	36	p2.7	56	ad3	76	rfsn_n
17	lcs_n	37	p2.6	57	a11	77	s2_n
18	ucs_n	38	cts0_n	58	ad4	78	s1_n
19	int0	39	txd0	59	a12	79	s0_n
20	int1	40	rxd0	60	ad5	80	den_n

2.1.9 LQFP Physical Dimensions

The physical dimensions for the 80 LQFP are as shown in Figure 9.

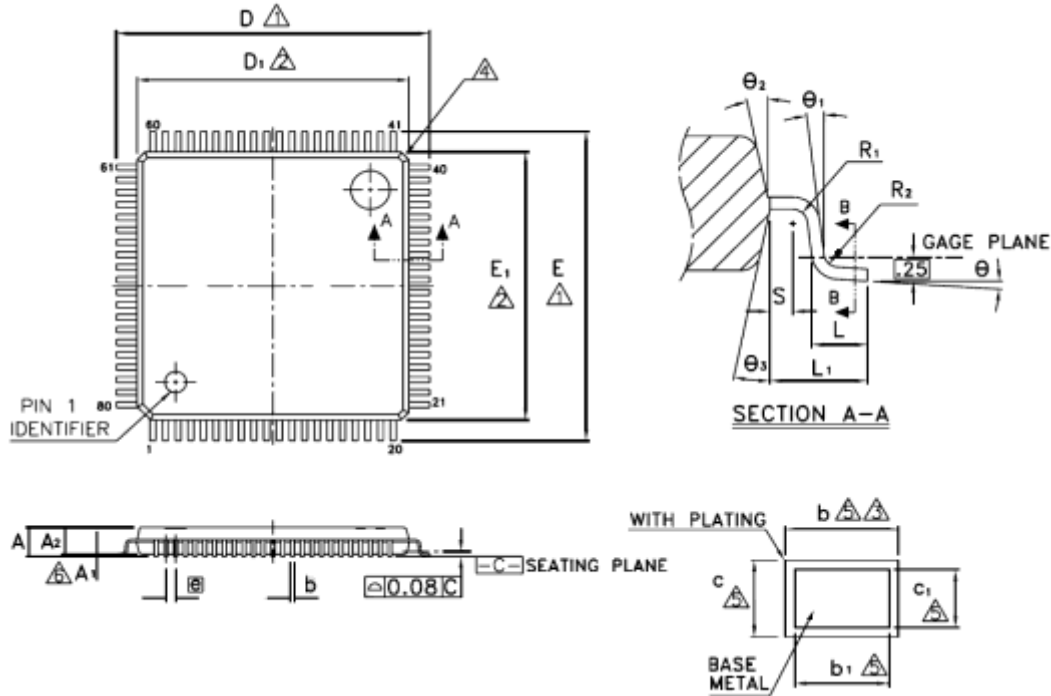

Legend:

Symbol	Dimension in mm			Dimension in Inch		
	Min	Nom	Max	Min	Mom	Max
A	—	—	1.60	—	—	0.063
A ₁	0.05	—	0.15	0.002	—	0.006
A ₂	1.35	1.40	1.45	0.053	0.055	0.057
b	0.17	0.22	0.27	0.007	0.009	0.011
b ₁	0.17	0.20	0.23	0.007	0.008	0.009
c	0.09	—	0.20	0.004	—	0.008
c ₁	0.09	—	0.16	0.004	—	0.006
D	14.00 BSC			0.551 BSC		
D ₁	12.00 BSC			0.472 BSC		
E	14.00 BSC			0.551 BSC		
E ₁	12.00 BSC			0.472 BSC		
e	0.50 BSC			0.020 BSC		
L	0.45	0.60	0.75	0.018	0.024	0.030
L ₁	1.00 REF			0.039 REF		
R ₁	0.08	—	—	0.003	—	—
R ₂	0.08	—	0.20	0.003	—	0.008
S	0.20	—	—	0.008	—	—
θ	0°	3.5°	7°	0°	3.5°	7°
θ ₁	0°	—	—	0°	—	—
θ ₂	11°	12°	13°	11°	12°	13°
θ ₃	11°	12°	13°	11°	12°	13°

1. To be determined at seating plane C.
2. Dimensions D₁ and E₁ do not include mold protrusion. D₁ and E₁ are maximum plastic body size dimensions including mold mismatch.
3. Dimension b does not include dambar protrusion. Dambar cannot be located on the lower radius of the foot.
4. Exact shape of each corner is optional.
5. These dimensions apply to the flat section of the lead between 0.10 and 0.25mm from the lead tip.
6. A₁ is defined as the distance from the seating plane to the lowest point of the package body.

Notes:

1. Exact shape of each corner is optional.
2. Controlling dimension: mm.

Figure 9. 80-Pin LQFP Physical Package Dimensions

2.2 IA186EB Pin/Signal Descriptions

Descriptions of the pin and signal functions for the IA186EB microcontroller are provided in Table 7.

Several of the IA186EB pins have different functions depending on the operating mode of the device. Each of the different signals supported by a pin is listed and defined in Table 7—indexed alphabetically in the first column of the table. Additionally, the name of the pin associated with the signal as well as the pin numbers for the PLCC, LQFP, and PQFP packages are provided in the “Pin” column. Signals not used in a specific package type are designated “NA.”

Table 7. IA186EB Pin/Signal Descriptions

Signal	Pin				Description
	Name	PLCC	LQFP	PQFP	
a16 (output only)	a16	80	66	29	address Bits [16–19]. Input/Output. These pins provide the four most-significant bits of the Address Bus. During the address portion of the IA186EB bus cycle, Address Bits [16–19] are presented on the bus and can be latched using the ale signal (see table entry). During the data portion of the IA186EB bus cycle, these lines are driven to a logic 0.
a17 (output only)	a17	81	67	30	
a18 (output only)	a18	82	68	31	
a19	a19/once_n	83	69	32	
ad0	ad0	61	47	10	address/data Bits [0–15]. Input/Output. These pins provide the multiplexed Address Bus and Data Bus. During the address portion of the IA186EB bus cycle, Address Bits [0–15] are presented on the bus and can be latched using the ale signal (see next table entry). During the data portion of the IA186EB bus cycle, 8- or 16-bit data are present on these lines.
ad1	ad1	66	52	15	
ad2	ad2	68	54	17	
ad3	ad3	70	56	19	
ad4	ad4	72	58	21	
ad5	ad5	74	60	23	
ad6	ad6	76	62	25	
ad7	ad7	78	64	27	
ad8	ad8	62	48	11	
ad9	ad9	67	53	16	
ad10	ad10	69	55	18	
ad11	ad11	71	57	20	
ad12	ad12	73	59	22	
ad13	ad13	75	61	24	
ad14	ad14	77	63	26	
ad15	ad15	79	65	28	

Table 7. IA186EB Pin/Signal Descriptions (Continued)

Signal	Pin				Description															
	Name	PLCC	LQFP	PQFP																
ale	ale	6	75	38	address latch enable . Output. Active High. This signal is used to latch the address information during the address portion of a bus cycle.															
bclk0	p2.5/ bclk0	54	41	4	baud clock , Serial Port 0. Input. The bclk0 pin can be used to provide an alternate clock source for Serial Port 0. The input clock rate cannot be greater than one-half the operating frequency of the IA186EB.															
bclk1	p2.2/ bclk1	59	46	9	baud clock , Serial Port 1. Input. The bclk1 pin can be used to provide an alternate clock source for Serial Port 1. The input clock rate cannot be greater than one-half the operating frequency of the IA186EB.															
bhe_n	bhe_n	7	76	39	byte high enable . Output. Active Low. When bhe_n is asserted (low), it indicates that the bus cycle in progress is transferring data over the upper half of the data bus. Additionally, bhe_n and ad0 encode the following bus information: <table border="0"> <tr> <td>ad0</td> <td>bhe_n</td> <td>Bus Status</td> </tr> <tr> <td>0</td> <td>0</td> <td>Word Transfer</td> </tr> <tr> <td>0</td> <td>1</td> <td>Even Byte Transfer</td> </tr> <tr> <td>1</td> <td>0</td> <td>Odd Byte Transfer</td> </tr> <tr> <td>1</td> <td>1</td> <td>Refresh Operation</td> </tr> </table>	ad0	bhe_n	Bus Status	0	0	Word Transfer	0	1	Even Byte Transfer	1	0	Odd Byte Transfer	1	1	Refresh Operation
ad0	bhe_n	Bus Status																		
0	0	Word Transfer																		
0	1	Even Byte Transfer																		
1	0	Odd Byte Transfer																		
1	1	Refresh Operation																		
bhe_n is multiplexed with refresh_n	bhe_n is multiplexed with refresh_n				Note: bhe_n is multiplexed with refresh_n.															
busy	test_n/ busy	14	NA	NA	busy . Input. Active High. When the busy input is asserted, it causes the IA186EB to suspend operation during the execution of the Intel 80C187 Numerics Coprocessor instructions. Operation resumes when the pin is sampled low. <i>This applies to the PLCC package only.</i>															

Table 7. IA186EB Pin/Signal Descriptions (Continued)

Signal	Pin				Description
	Name	PLCC	LQFP	PQFP	
clk _{in}	clk _{in}	41	28	71	<p>clock input. Input. The clk_{in} pin is the input connection for an external clock. An external oscillator operating at two times the required processor operating frequency can be connected to this pin.</p> <p>If a crystal is used to supply the clock, it is connected between the clk_{in} pin and the osc_{out} pin (see osc_{out} table entry). When a crystal is connected, it drives an internal Pierce oscillator to the IA186EB.</p>
clk _{out}	clk _{out}	44	31	74	<p>clock output. Output. The clk_{out} pin provides a timing reference for inputs and outputs of the IA186EB. This clock output is one-half the input clock (clk_{in}) frequency. The clk_{out} signal has a 50% duty cycle, transitioning every falling edge of clk_{in}.</p>
cts0 _n	cts0 _n	51	38	1	<p>clear to send, Serial Port 0. Input. Active Low. When this input is high (i.e., not asserted), data transmission from Serial Port 0 is inhibited. When the signal is asserted (low), data transmission is permitted.</p>
cts1 _n	p2.4/cts1 _n	56	43	6	<p>clear to send, Serial Port 1. Input. Active Low. When this input is high (i.e., not asserted), data transmission from Serial Port 1 is inhibited. When the signal is asserted (low), data transmission is permitted.</p>
den _n	den _n	11	80	43	<p>data enable. Output. Active Low. This signal is used to enable of bidirectional transceivers in a buffered system. The den_n signal is asserted (low) only when data is to be transferred on the bus.</p>
dt/r _n	dt/r _n	16	NA	NA	<p>data transmit/receive. Output. This signal is used to control the direction of data flow for bidirectional buffers in a buffered system. When dt/r_n is high, the direction indicated is transmit; when dt/t_n is low, the direction indicated is receive.</p>
error _n	error _n	3	NA	NA	<p>error. Input. Active Low. When this signal is asserted (low), it indicates that the last numerics coprocessor operation resulted in an exception condition.</p>

Table 7. IA186EB Pin/Signal Descriptions (Continued)

Signal	Pin				Description
	Name	PLCC	LQFP	PQFP	
gcs0_n	p1.0/ gcs0_n	28	16	59	generic chip select n (n = 0–7). Output. Active Low. When programmed and enabled, each of these pins provide a chip select signal that will be asserted (low) whenever the address of a memory or I/O bus cycle is within the address space programmed for that output.
gcs1_n	p1.1/ gcs1_n	27	15	58	
gcs2_n	p1.2/ gcs2_n	26	14	57	
gcs3_n	p1.3/ gcs3_n	25	13	56	
gcs4_n	p1.4/ gcs4_n	24	12	55	
gcs5_n	p1.5/ gcs5_n	21	9	52	
gcs6_n	p1.6/ gcs6_n	20	8	51	
gcs7_n	p1.7/ gcs7_n	19	7	50	
hlda	hlda	12	1	44	hold acknowledge . Output. Active High. When hlda is asserted (high), it indicates that the IA186EB has relinquished control of the local bus to another bus master in response to a HOLD request (see next table entry). When hlda is asserted, the IA186EB data bus and control signals float, allowing another bus master to drive the signals directly.
hold	hold	13	2	45	hold . Input. Active High. This signal is a request indicating that an external bus master wishes to gain control of the local bus. The IA186EB will relinquish control of the local bus between instruction boundaries not conditioned by a LOCK prefix.
int0 (input)	int0 (input only)	31	19	62	interrupt n (n = 0-4). Input/Output. Active High. These maskable inputs interrupt program flow and cause execution to continue at an interrupt vector of a specific interrupt type as follows: int0 : Type 12 int1 : Type 13 int2 : Type 14 int3 : Type 15 int4 : Type 17 To allow interrupt expansion, int0 and int1 can be used with the interrupt acknowledge signals inta0_n and inta1_n (see next table entries) to serve as external interrupt inputs or interrupt acknowledge outputs.
int1 (input)	int1 (input only)	32	20	63	
int2	int2/inta0_n	33	21	64	
int3	int3/inta1_n	34	22	65	
int4 (input)	int4 (input only)	35	23	66	
inta0_n	int2/inta0_n	33	21	64	interrupt acknowledge 0 . Input/Output. Active Low. This pin provides an interrupt acknowledge handshake in response to an interrupt request on the int0 pin (see previous table entry).

Table 7. IA186EB Pin/Signal Descriptions (Continued)

Signal	Pin				Description
	Name	PLCC	LQFP	PQFP	
inta1_n	int3/inta1_n	34	22	65	interrupt acknowledge 1. Input/Output. Active Low. This pin provides an interrupt acknowledge handshake in response to an interrupt request on the int1 pin (see previous table entry).
lcs_n	lcs_n	29	17	60	lower chip select. Output. Active Low. This pin provides a chip select signal that will be asserted (low) whenever the address of a memory bus cycle is within the address space programmed for that output.
lock_n	lock_n	15	4	47	lock. Output. Active Low. When asserted (low), this signal indicates that the bus cycle in progress is cannot be interrupted. While lock_n is active, the IA186EB will not service bus requests such as HOLD.
ncs_n	ncs_n	60	NA	NA	numerics coprocessor select. Output. Active Low. This signal is asserted (low) when the IA186EB accesses an Intel 80C187 Numerics Coprocessor.
nmi	nmi	17	5	48	non-maskable interrupt. Input. Active High. When the nmi signal is asserted (high) it causes a Type 2 interrupt to be serviced by the IA186EB. Note: The assertion of nmi is latched internally by the IA186EB.
once_n	a19/once_n	83	69	32	on-circuit emulation. Input. Active Low. Note: ONCE Mode is used for device testing. If the once_n pin is driven low during a reset operation, all IA186EB output and input/output pins are placed in a high-impedance state. This pin is weakly held high while resin_n is active.

Table 7. IA186EB Pin/Signal Descriptions (Continued)

Signal	Pin				Description
	Name	PLCC	LQFP	PQFP	
oscout	oscout	40	27	70	<p>oscillator output. Output. The oscout pin is the output connection for an external crystal that drives the IA186EB internal Pierce oscillator. (When an external crystal is used, it is connected between this pin and the clkin pin. See clkin table entry.)</p> <p>Note: If an external oscillator or clock source is used to drive the IA186EB instead of a crystal, oscout must be left unconnected (i.e., must float). When the IA186EB is operating in the ONCE mode, oscout does not float.</p>
p1.0	p1.0/gcs0_n	28	16	59	<p>port 1, Bit [N] (N = 0–7). Output. Each pin of Port 1, p1.0–p1.7, can function individually as a general-purpose output line.</p>
p1.1	p1.1/gcs1_n	27	15	58	
p1.2	p1.2/gcs2_n	26	14	57	
p1.3	p1.3/gcs3_n	25	13	56	
p1.4	p1.4/gcs4_n	24	12	55	
p1.5	p1.5/gcs5_n	21	9	52	
p1.6	p1.6/gcs6_n	20	8	51	
p1.7	p1.7/gcs7_n	19	7	50	
p2.0	p2.0/rxd1	57	44	7	port 2, Bit [0]. Input/Output. This pin functions as a general-purpose I/O line.
p2.1	p2.1/txd1	58	45	8	port 2, Bit [1]. Output. This pin functions as a general-purpose output line.
p2.2	p2.2/bclk1	59	46	9	port 2, Bit [2]. Input. This pin functions as a general-purpose input line.
p2.3	p2.3/sint1	55	42	5	port 2, Bit [3]. Output. This pin functions as a general-purpose output line.
p2.4	p2.4/cts1_n	56	43	6	port 2, Bit [4]. Input. This pin functions as a general-purpose input line.
p2.5	p2.5/bclk0	54	41	4	port 2, Bit [5]. Input. This pin functions as a general-purpose input line.
p2.6	p2.6	50	37	80	port 2, Bit [6]. Input/Output (open drain). This pin functions as a general-purpose bidirectional input/output line.
p2.7	p2.7	49	36	79	port 2, Bit [7]. Input/Output (open drain). This pin functions as a general-purpose bidirectional input/output line.

Table 7. IA186EB Pin/Signal Descriptions (Continued)

Signal	Pin				Description
	Name	PLCC	LQFP	PQFP	
pdtmr	pdtmr	36	24	67	<p>power-down timer. Input/Output (push-pull). Note: The IA186EB enters Powerdown Mode when the PWRDN bit in the Power Control Register is set to 1 and a HALT instruction is executed. Exit from the Powerdown Mode occurs upon receipt of a non-maskable interrupt (i.e., assertion of the nmi input) or a reset (i.e., assertion of the resin_n input).</p> <p>The pdtmr pin, which is normally connected to an external capacitor, determines the amount of time that the IA186EB waits before resuming normal operation after an exit from the Powerdown when a non-maskable interrupt is received—essentially a delay between the assertion of the nmi input and the enabling of the IA186EB internal clocks. The delay required depends on the start-up characteristics of the crystal oscillator.</p> <p>The pdtmr pin does not apply when the Powerdown Mode is exited by the receipt of a reset (i.e., the assertion resin_n).</p>
pereq	pereq	39	NA	NA	<p>numerics coprocessor external request. Input. Active High. When asserted (high), this signal indicates that a data transfer between an Intel 80C187 Numerics Coprocessor and memory is pending. <i>This applies to the PLCC only.</i></p>
rd_n	rd_n	4	73	36	<p>read. Output. Active Low. When asserted (low), rd_n indicates that the accessed memory or I/O device must drive data from the location being accessed onto the data bus.</p>
ready	ready	18	6	49	<p>ready. Input. Active High. When asserted (high) the ready line indicates a bus-cycle completion. This signal must be active to terminate any bus cycle unless the IA186EB Chip-Select Unit is configured to ignore ready.</p>
resin_n	resin_n	37	25	68	<p>reset input. Input. Active Low. When resin_n is asserted (low), the IA186EB immediately terminates any bus cycle in progress and assumes an initialized state. All pins are driven to a known state, and resout (see next table entry) is asserted.</p>

Table 7. IA186EB Pin/Signal Descriptions (Continued)

Signal	Pin				Description																																				
	Name	PLCC	LQFP	PQFP																																					
resout	resout	38	26	69	reset output. Output. Active High. When resout is asserted, it indicates that the IA186EB is being reset. The resout signal will remain active (high) as long as resin_n remains active (low).																																				
rxd0	rxd0	53	40	3	Receive (rx) data, Serial Port 0. Input/Output. This pin is the serial data input for Serial Port 0. During synchronous serial communications, rxd0 is bidirectional and functions as an output for data transmission (txd0 becomes the clock).																																				
rxd1	p2.0/ rxd1	57	44	7	Receive (rx) data, Serial Port 1. Input/Output. This pin is the serial data input for Serial Port 1. During synchronous serial communications, rxd1 is bidirectional and functions as an output for data transmission (txd1 becomes the clock).																																				
s0_n	s0_n	10	79	42	statusN (N = 0–2). Output. During a bus cycle the status (i.e., type) of cycle is encoded on these lines as follows: <table border="1"> <thead> <tr> <th>s2_n</th> <th>s1_n</th> <th>s0_n</th> <th>Bus Cycle Status</th> </tr> </thead> <tbody> <tr> <td>0</td> <td>0</td> <td>0</td> <td>Interrupt Acknowledge</td> </tr> <tr> <td>0</td> <td>0</td> <td>1</td> <td>Read I/O</td> </tr> <tr> <td>0</td> <td>1</td> <td>0</td> <td>Write I/O</td> </tr> <tr> <td>0</td> <td>1</td> <td>1</td> <td>Processor HALT</td> </tr> <tr> <td>1</td> <td>0</td> <td>0</td> <td>Queue Instruction Fetch</td> </tr> <tr> <td>1</td> <td>0</td> <td>1</td> <td>Read Memory</td> </tr> <tr> <td>1</td> <td>1</td> <td>0</td> <td>Write Memory</td> </tr> <tr> <td>1</td> <td>1</td> <td>1</td> <td>No Bus Activity</td> </tr> </tbody> </table>	s2_n	s1_n	s0_n	Bus Cycle Status	0	0	0	Interrupt Acknowledge	0	0	1	Read I/O	0	1	0	Write I/O	0	1	1	Processor HALT	1	0	0	Queue Instruction Fetch	1	0	1	Read Memory	1	1	0	Write Memory	1	1	1	No Bus Activity
s2_n	s1_n	s0_n	Bus Cycle Status																																						
0	0	0	Interrupt Acknowledge																																						
0	0	1	Read I/O																																						
0	1	0	Write I/O																																						
0	1	1	Processor HALT																																						
1	0	0	Queue Instruction Fetch																																						
1	0	1	Read Memory																																						
1	1	0	Write Memory																																						
1	1	1	No Bus Activity																																						
s1_n	s1_n	9	78	41																																					
s2_n	s2_n	8	77	40																																					
sint1	p2.3/ sint1	55	42	5	serial interrupt, Serial Port 1. Output. Active High. When sint1 is asserted (high), it indicates that Serial Port 1 requires service.																																				
t0in	t0in	46	33	76	timer 0 input. Input. Depending on the Timer Mode programmed for Timer 0, this input is used either as clock input or a control signal.																																				
t0out	t0out	45	32	75	timer 0 output. Output. Depending on the Timer Mode programmed for Timer 0, this output can provide a single clock or a continuous waveform.																																				
t1in	t1in	48	35	78	timer 1 input. Input. Depending on the Timer Mode programmed for Timer 1, this input is used either as clock input or a control signal.																																				

Table 7. IA186EB Pin/Signal Descriptions (Continued)

Signal	Pin				Description
	Name	PLCC	LQFP	PQFP	
t1out	t1out	47	34	77	timer 1 output. Output. Depending on the Timer Mode programmed for Timer 1, this output can provide a single clock or a continuous waveform.
test_n	test_n /busy	14	3	46	test. Input. Active Low. When the test_n input is high (i.e., not asserted), it causes the IA186EB to suspend operation during the execution of the WAIT instruction. Operation resumes when the pin is sampled low (asserted).
txd0	txd0	52	39	2	Transmit (tx) data, Serial Port 0 . Output. This pin is the serial data output for Serial Port 0. During synchronous serial communications, txd0 becomes the transmit clock (rx d0 functions as an output for data transmission).
txd1	p2.1/ txd1	58	45	8	Transmit (tx) data, Serial Port 1 . Output. This pin is the serial data output for Serial Port 1. During synchronous serial communications, txd1 becomes the transmit clock (rx d1 functions as an output for data transmission).
ucs_n	ucs_n	30	18	61	upper chip select. Output. Active Low. This pin provides a chip select signal that will be asserted (low) whenever the address of a memory bus cycle is within the address space programmed for that output.
V _{cc}	V _{cc}	1, 23, 42, 64	11, 29, 50, 71	13, 34, 54, 72	Power (V _{cc}). This pin provides power for the IA186EB device. It must be connected to a +5V DC power source.
V _{ss}	V _{ss}	2, 22, 43, 63, 65, 84	10, 30, 49, 51, 70, 72	12, 14, 33, 35, 53, 73	Ground (V _{ss}). This pin provides the digital ground (0V) for the IA186EB. It must be connected to a V _{ss} board plane.
wr_n	wr_n	5	74	37	write. Output. Active Low. When asserted (low), wr_n indicates that data available on the data bus are to be latched into the accessed memory or I/O device.

2.3 IA188EB Pin/Signal Descriptions

Descriptions of the pin and signal functions for the IA188EB microcontroller are provided in Table 8.

Several of the IA188EB pins have different functions depending on the operating mode of the device. Each of the different signals supported by a pin is listed and defined in Table 8—indexed alphabetically in the first column of the table. Additionally, the name of the pin associated with the signal as well as the pin numbers for the PLCC, LQFP, and LQFP packages are provided in the “Pin” column.

Table 8. IA188EB Pin/Signal Descriptions

Signal	Pin				Description
	Name	PLCC	LQFP	PQFP	
a8	a8	62	48	11	address Bits [8-19]. Output. These pins provide the 12 most-significant bits of the Address Bus. During the entire IA188EB bus cycle, Address Bits [8–19] are presented on the bus and can be latched using the ale signal (see table entry).
a9	a9	67	53	16	
a10	a10	69	55	18	
a11	a11	71	57	20	
a12	a12	73	59	22	
a13	a13	75	61	24	
a14	a14	77	63	26	
a15	a15	79	65	28	
a16	a16	80	66	29	
a17	a17	81	67	30	
a18	a18	82	68	31	address/data Bits [0-7]. Input/Output. These pins provide a multiplexed Address Bus and Data Bus. During the address portion of the IA188EB bus cycle, Address Bits [0–7] are presented on the bus and can be latched using the ale signal (see next table entry). During the data portion of the IA188EB bus cycle, 8-bit data are present on these lines.
a19	a19/once_n	83	69	32	
ad0	ad0	61	47	10	
ad1	ad1	66	52	15	
ad2	ad2	68	54	17	
ad3	ad3	70	56	19	
ad4	ad4	72	58	21	
ad5	ad5	74	60	23	
ad6	ad6	76	62	25	
ad7	ad7	78	64	27	
ale	ale	6	75	38	address latch enable. Output. Active High. This signal is used to latch the address information during the address portion of a bus cycle.
bclk0	p2.5/bclk0	54	41	4	baud clock, Serial Port 0. Input. The bclk0 pin can be used to provide an alternate clock source for Serial Port 0. The input clock rate cannot be greater than one-half the operating frequency of the IA188EB.

Table 8. IA188EB Pin/Signal Descriptions (Continued)

Signal	Pin				Description
	Name	PLCC	LQFP	PQFP	
bclk1	p2.2/ bclk1	59	46	9	baud clock , Serial Port 1. Input. The bclk1 pin can be used to provide an alternate clock source for Serial Port 1. The input clock rate cannot be greater than one-half the operating frequency of the IA188EB.
clk _{in}	clk _{in}	41	28	71	clock input . Input. The clk_{in} pin is the input connection for an external clock. An external oscillator, operating at two times the required processor operating frequency, can be connected to this pin. If a crystal is used to supply the clock, it is connected between the clk_{in} pin and the osc_{out} pin (see osc_{out} table entry). When a crystal is connected, it drives an internal Pierce oscillator to the IA188EB.
clk _{out}	clk _{out}	44	31	74	clock output . Output. The clk_{out} pin provides a timing reference for inputs and outputs of the IA188EB. This clock output is one-half the input clock (clk_{in}) frequency. The clk_{out} signal has a 50% duty cycle, transitioning every falling edge of clk_{in} .
cts0 _n	cts0 _n	51	38	1	clear to send , Serial Port 0. Input. Active Low. When this input is high (i.e., not asserted), data transmission from Serial Port 0 is inhibited. When the signal is asserted (low), data transmission is permitted.
cts1 _n	p2.4/ cts1_n	56	43	6	clear to send , Serial Port 1. Input. Active Low. When this input is high (i.e., not asserted), data transmission from Serial Port 1 is inhibited. When the signal is asserted (low), data transmission is permitted.
den _n	den _n	11	80	43	data enable . Output. Active Low. This signal is used to enable of bidirectional transceivers in a buffered system. The den_n signal is asserted (low) only when data are to be transferred on the bus.
dt/r _n	dt/r _n	16	NA	NA	data transmit/receive . Output. This signal is used to control the direction of data flow for bidirectional buffers in a buffered system. When dt/r_n is high, the direction indicated is transmit; when dt/t_n is low, the direction indicated is receive.

Table 8. IA188EB Pin/Signal Descriptions (Continued)

Signal	Pin				Description
	Name	PLCC	LQFP	PQFP	
gcs0_n	p1.0/ gcs0_n	28	16	59	generic chip select n (n = 0–7). Output. Active Low. When programmed and enabled, each of these pins provide a chip select signal that will be asserted (low) whenever the address of a memory or I/O bus cycle is within the address space programmed for that output.
gcs1_n	p1.1/ gcs1_n	27	15	58	
gcs2_n	p1.2/ gcs2_n	26	14	57	
gcs3_n	p1.3/ gcs3_n	25	13	56	
gcs4_n	p1.4/ gcs4_n	24	12	55	
gcs5_n	p1.5/ gcs5_n	21	9	52	
gcs6_n	p1.6/ gcs6_n	20	8	51	
gcs7_n	p1.7/ gcs7_n	19	7	50	
hlda	hlda	12	1	44	hold acknowledge . Output. Active High. When hlda is asserted (high), it indicates that the IA188EB has relinquished control of the local bus to another bus master in response to a HOLD request (see next table entry). When hlda is asserted, the IA188EB data bus and control signals are floated, allowing another bus master to drive the signals directly.
hold (input)	hold (input)	13	2	45	hold . Input. Active High. This signal is a request indicating that an external bus master wishes to gain control of the local bus. The IA188EB will relinquish control of the local bus between instruction boundaries not conditioned by a lock prefix.
int0 (input)	int0 (input only)	31	19	62	interrupt N (N = 0–4). Input/Output. Active High. These maskable inputs interrupt program flow and cause execution to continue at an interrupt vector of a specific interrupt type as follows: int0 : Type 12 int1 : Type 13 int2 : Type 14 int3 : Type 15 int4 : Type 17 To allow interrupt expansion, int0 and int1 can be used with the interrupt acknowledge signals inta0_n and inta1_n (see next table entries) to serve as external interrupt inputs or interrupt acknowledge outputs.
int1 (input)	int1 (input only)	32	20	63	
int2	int2/inta0_n	33	21	64	
int3	int3/inta1_n	34	22	65	
int4 (input)	int4 (input only)	35	23	66	
inta0_n	int2/inta0_n	33	21	64	interrupt acknowledge 0 . Output. Active Low. This pin provides an interrupt acknowledge handshake in response to an interrupt request on the int0 pin (see previous table entry).

Table 8. IA188EB Pin/Signal Descriptions (Continued)

Signal	Pin			Description	
	Name	PLCC	LQFP		PQFP
inta1_n	int3/inta1_n	34	22	65	interrupt acknowledge 1. Input/Output. Active Low. This pin provides an interrupt acknowledge handshake in response to an interrupt request on the int1 pin (see previous table entry).
lcs_n	lcs_n	29	17	60	lower chip select. Input/Output. Active Low. This pin provides a chip select signal that will be asserted (low) whenever the address of a memory bus cycle is within the address space programmed for that output.
lock_n	lock_n	15	4	47	lock. Output. Active Low. When asserted (low), this signal indicates that the bus cycle in progress is cannot be interrupted. While lock_n is active, the IA188EB will not service bus requests such as HOLD.
nmi	nmi	17	5	48	non-maskable interrupt. Input. Active High. When the nmi signal is asserted (high), it causes a Type 2 interrupt to be serviced by the IA188EB. Note: The assertion of nmi is latched internally by the IA188EB.
once_n	a19/once_n	83	69	32	on-circuit emulation. Input. Active Low. Note: ONCE Mode is used for device testing. If the once_n pin is driven low during reset, all IA188EB output and input/output pins are placed in a high-impedance state. This pin is weakly held high while resin_n is active.
oscout	oscout	40	27	70	oscillator output. Output. The oscout pin is the output connection for an external crystal that drives the IA188EB internal Pierce oscillator. (When an external crystal is used, it is connected between this pin and the clkin pin—see clkin table entry.) Note: If an external oscillator or clock source is used to drive the IA188EB instead of a crystal, oscout must be left unconnected (i.e., must float). When the IA188EB is operating in the ONCE mode, oscout does not float.

Table 8. IA188EB Pin/Signal Descriptions (Continued)

Signal	Pin				Description
	Name	PLCC	LQFP	PQFP	
p1.0	p1.0/gcs0_n	28	16	59	port 1, Bit [N] (N = 0–7). Output. Each pin of Port 1, p1.0–p1.7 , can function individually as a general-purpose output line.
p1.1	p1.1/gcs1_n	27	15	58	
p1.2	p1.2/gcs2_n	26	14	57	
p1.3	p1.3/gcs3_n	25	13	56	
p1.4	p1.4/gcs4_n	24	12	55	
p1.5	p1.5/gcs5_n	21	9	52	
p1.6	p1.6/gcs6_n	20	8	51	
p1.7	p1.7/gcs7_n	19	7	50	
p2.0	p2.0/rxd1	57	44	7	port 2, Bit [0] . Input/Output. This pin functions as a general-purpose I/O line.
p2.1	p2.1/txd1	58	45	8	port 2, Bit [1] . Output. This pin functions as a general-purpose output line.
p2.2	p2.2/bclk1	59	46	9	port 2, Bit [2] . Input. This pin functions as a general-purpose input line.
p2.3	p2.3/sint1	55	42	5	port 2, Bit [3] . Output. This pin functions as a general-purpose output line.
p2.4	p2.4/cts1_n	56	43	6	port 2, Bit [4] . Input. This pin functions as a general-purpose input line.
p2.5	p2.5/bclk0	54	41	4	port 2, Bit [5] . Input. This pin functions as a general-purpose input line.
p2.6	p2.6	50	37	80	port 2, Bit [6] . Input/Output (open drain). This pin functions as a general-purpose bidirectional input/output line.
p2.7	p2.7	49	36	79	port 2, Bit [7] . Input/Output (open drain). This pin functions as a general-purpose bidirectional input/output line.

Table 8. IA188EB Pin/Signal Descriptions (Continued)

Signal	Pin				Description
	Name	PLCC	LQFP	PQFP	
pdtmr	pdtmr	36	24	67	<p>Power-down timer. Input/Output (push-pull). Note: The IA188EB enters Powerdown Mode when the PWRDN bit in the Power Control Register is set to 1 and a HALT instruction is executed. Exit from the Powerdown Mode occurs upon receipt of a non-maskable interrupt (i.e., assertion of the nmi input) or a reset (i.e., assertion of the resin_n input).</p> <p>The pdtmr pin, which is normally connected to an external capacitor, determines the amount of time that the IA188EB waits before resuming normal operation after an exit from the Powerdown when a non-maskable interrupt is received—essentially a delay between the assertion of the nmi input and the enabling of the IA188EB internal clocks. The delay required depends on the start-up characteristics of the crystal oscillator.</p> <p>The pdtmr pin does not apply when the Powerdown Mode is exited by the receipt of a reset (i.e., the assertion resin_n).</p>
rd_n	rd_n	4	73	36	<p>read. Output. Active Low. When asserted (low), rd_n indicates that the accessed memory or I/O device must drive data from the location being accessed onto the data bus.</p>
ready	ready	18	6	49	<p>ready. Input. Active High. When asserted (high) the ready line indicates the completion of a bus cycle. This signal must be active to terminate any bus cycle unless the IA188EB Chip-Select Unit is configured to ignore ready.</p>
resin_n	resin_n	37	25	68	<p>reset input. Input. Active Low. When resin_n is asserted (low), the IA188EB immediately terminates any bus cycle in progress and assumes an initialized state. All pins are driven to a known state, and resout (see next table entry) is asserted.</p>
resout	resout	38	26	69	<p>reset output. Output. Active High. When resout is asserted, it indicates that the IA188EB is being reset. The resout signal will remain active (high) as long as resin_n remains active (low).</p>
rfsh_n	rfsh_n	7	76	39	<p>refresh. Output. Active Low. When rfsh_n is asserted (low), it indicates that a refresh cycle is in progress.</p>

Table 8. IA188EB Pin/Signal Descriptions (Continued)

Signal	Pin			Description																																					
	Name	PLCC	LQFP		PQFP																																				
rxd0	rxd0	53	40	3	Receive (rx) data, Serial Port 0. Input/Output. This pin is the serial data input for Serial Port 0. During synchronous serial communications, rxd0 is bidirectional and functions as an output for data transmission (txd0 becomes the clock).																																				
rxd1	p2.0/rxd1	57	44	7	Receive (rx) data, Serial Port 1. Input/Output. This pin is the serial data input for Serial Port 1. During synchronous serial communications, rxd1 is bidirectional and functions as an output for data transmission (txd1 becomes the clock).																																				
s0_n	s0_n	10	79	42	statusN (N = 0–2). Output. During a bus cycle the status (i.e., type) of cycle is encoded on these lines as follows: <table border="1"> <thead> <tr> <th>s2_n</th> <th>s1_n</th> <th>s0_n</th> <th>Bus Cycle Status</th> </tr> </thead> <tbody> <tr> <td>0</td> <td>0</td> <td>0</td> <td>Interrupt Acknowledge</td> </tr> <tr> <td>0</td> <td>0</td> <td>1</td> <td>Read I/O</td> </tr> <tr> <td>0</td> <td>1</td> <td>0</td> <td>Write I/O</td> </tr> <tr> <td>0</td> <td>1</td> <td>1</td> <td>Processor HALT</td> </tr> <tr> <td>1</td> <td>0</td> <td>0</td> <td>Queue Instruction Fetch</td> </tr> <tr> <td>1</td> <td>0</td> <td>1</td> <td>Read Memory</td> </tr> <tr> <td>1</td> <td>1</td> <td>0</td> <td>Write Memory</td> </tr> <tr> <td>1</td> <td>1</td> <td>1</td> <td>No Bus Activity</td> </tr> </tbody> </table>	s2_n	s1_n	s0_n	Bus Cycle Status	0	0	0	Interrupt Acknowledge	0	0	1	Read I/O	0	1	0	Write I/O	0	1	1	Processor HALT	1	0	0	Queue Instruction Fetch	1	0	1	Read Memory	1	1	0	Write Memory	1	1	1	No Bus Activity
s2_n	s1_n	s0_n	Bus Cycle Status																																						
0	0	0	Interrupt Acknowledge																																						
0	0	1	Read I/O																																						
0	1	0	Write I/O																																						
0	1	1	Processor HALT																																						
1	0	0	Queue Instruction Fetch																																						
1	0	1	Read Memory																																						
1	1	0	Write Memory																																						
1	1	1	No Bus Activity																																						
s1_n	s1_n	9	78	41																																					
s2_n	s2_n	8	77	40																																					
sint1	p2.3/sint1	55	42	5	serial interrupt , Serial Port 1. Output. Active High. When sint1 is asserted (high), it indicates that Serial Port 1 requires service.																																				
t0in	t0in	46	33	76	timer 0 input . Input. Depending on the Timer Mode programmed for Timer 0, this input is used either as clock input or a control signal.																																				
t0out	t0out	45	32	75	timer 0 output . Output. Depending on the Timer Mode programmed for Timer 0, this output can provide a single clock or a continuous waveform.																																				
t1in	t1in	48	35	78	timer 1 input . Input. Depending on the Timer Mode programmed for Timer 1, this input is used either as clock input or a control signal.																																				
t1out	t1out	47	34	77	timer 1 output . Output. Depending on the Timer Mode programmed for Timer 1, this output can provide a single clock or a continuous waveform.																																				

Table 8. IA188EB Pin/Signal Descriptions (Continued)

Signal	Pin				Description
	Name	PLCC	LQFP	PQFP	
test_n	test_n	14	3	46	test . Input. Active Low. When the test_n input is high (i.e., not asserted), it causes the IA188EB to suspend operation during the execution of the WAIT instruction. Operation resumes when the pin is sampled low (asserted).
txd0	txd0	52	39	2	Transmit (tx) data, Serial Port 0. Output. This pin is the serial data output for Serial Port 0. During synchronous serial communications, txd0 becomes the transmit clock (rxd0 functions as an output for data transmission).
txd1	p2.1/txd1	58	45	8	Transmit (tx) data, Serial Port 1. Output. This pin is the serial data output for Serial Port 1. During synchronous serial communications, txd1 becomes the transmit clock (rxd1 functions as an output for data transmission).
ucs_n	ucs_n	30	18	61	upper chip select . Output. Active Low. This pin provides a chip select signal that will be asserted (low) whenever the address of a memory bus cycle is within the address space programmed for that output.
V _{cc}	V _{cc}	1, 23, 42, 64	11, 29, 50, 71	13, 34, 54, 72	Power (V _{cc}). This pin provides power for the IA188EB device. It must be connected to a +5V DC power source.
V _{ss}	V _{ss}	2, 22, 43, 63, 65, 84	10, 30, 49, 51, 70, 72	12, 14, 33, 35, 53, 73	Ground (V _{ss}). This pin provides the digital ground (0V) for the IA188EB. It must be connected to a V _{ss} board plane.
wr_n	wr_n	5	74	37	write . Output. Active Low. When asserted (low), wr_n indicates that data available on the data bus are to be latched into the accessed memory or I/O device.

3. Maximum Ratings, Thermal Characteristics, and DC Parameters

For the Innovasic Semiconductor IA186EB and IA188EB microcontrollers, the absolute maximum ratings, thermal characteristics, and DC parameters are provided in Tables 9 through 11, respectively.

Table 9. IA186EB and IA188EB Absolute Maximum Ratings

Parameter	Rating
Storage Temperature	-40°C to +125°C
Supply Voltage with Respect to v_{ss}	-0.3V to +6.0V
Voltage on Pins other than Supply with Respect to v_{ss}	-0.3V to +(V _{cc} + 0.3)V

Table 10. IA186EB and IA188EB Thermal Characteristics

Symbol	Characteristic	Value	Units
T_A	Ambient Temperature	-40°C to 85°C	°C
P_D	Power Dissipation	MHz × ICC × V/1000	W
Θ_{Ja}	84-Pin PLCC Package	30.7	°C/W
	80-Pin PQFP Package	46	
	80-Pin LQFP Package	52	
T_J	Average Junction Temperature	$T_A + (P_D \times \Theta_{Ja})$	°C

Table 11. IA186EB and IA188EB DC Parameters

Symbol	Parameter	Min	Max	Units	Notes
5.0V Operation V_{CC}	Supply Voltage	4.5	5.5	V	–
3.3V Operation V_{CC}	Supply Voltage	3.0	3.6	V	–
V_{IL}	Input Low Voltage	–0.3	0.3 V_{CC}	V	input hysteresis on $resin_n =$ 0.50V
V_{IH}	Input High Voltage	0.7 V_{CC}	$V_{CC} +$ 0.3	V	–
V_{OL}	Output Low Voltage $V_{CC} = 5.5V$ or $3.6V$	–	0.4	V	$I_{OL} = 12mA$
V_{OH}	Output High Voltage $V_{CC} = 4.5V/3.0V$	3.5/2.4	–	V	$I_{OH} = -12 mA$
I_{LEAK}	Input Leakage Current for Pins: $ad15-ad0$, $ad7-ad0$ (IA188EB), $ready$, $hold$, $resin_n$; clk in , $test_n$, nmi , $int4-int0$, $t0in$, $t1in$, $rdx0$, $bclk0_n$, $cts0_n$, $rx1$, $bclk1_n$, $cts1_n$, $p2.6$, $p2.7$	–	± 1	μA	$0V \leq V_{IN} \leq V_{CC}$
	Input Leakage Current for Pins (@3.3V): $pereq$	+ .147	+ .625	mA	$V_{IN} = V_{CC}$
	Input Leakage Current for Pins (@3.3V): $a19/once_n$, $a18-a16$, $lock_n$, $error_n$	– .147	– .625	mA	$V_{IN} = 0V$
	Input Leakage Current for Pins (@5V): $pereq$	+ .227	+ .833	mA	$V_{IN} = V_{CC}$
	Input Leakage Current for Pins (@5V): $a19/once_n$, $a18-a16$, $lock_n$, $error_n$	– .227	– .833	mA	$V_{IN} = 0V$
I_{LO}	Output Leakage Current	–	± 10	μA	$0.45 \leq V_{OUT} \leq$ V_{CC}
I_{ID}	Supply Current (IDLE) - @ 50 MHz	–	90	mA	–
C_{IN}	Input Pin Capacitance	0	5	pF	$T_F = 1 MHz$
C_{OUT}	Output Pin Capacitance	0	5	pF	$T_F = 1 MHz$
Operating temperature is -40°C to +85°C.					

4. Functional Description

4.1 Device Architecture

Architecturally, the IA186EB and IA188EB microcontrollers include the following functional modules:

- Bus Interface Unit
- Clock Generator
- Interrupt Control Unit
- Timer/Counter Unit
- Serial Communications Unit
- Chip-Select Unit
- I/O Port Unit
- Refresh Control Unit
- Power Management Unit

A functional block diagram of the IA186EB/IA188EB is shown in Figure 10. Descriptions of the functional modules are provided in the following subsections.

4.1.1 Bus Interface Unit

The IA186EB/IA188EB bus controller that generates local bus control signals and uses a hold/hlda protocol to share the local bus with other bus masters. The bus controller generates 20 address bits, read and write control signals, and bus-cycle status information. A ready input is used to extend a bus cycle beyond the minimum four clock cycles.

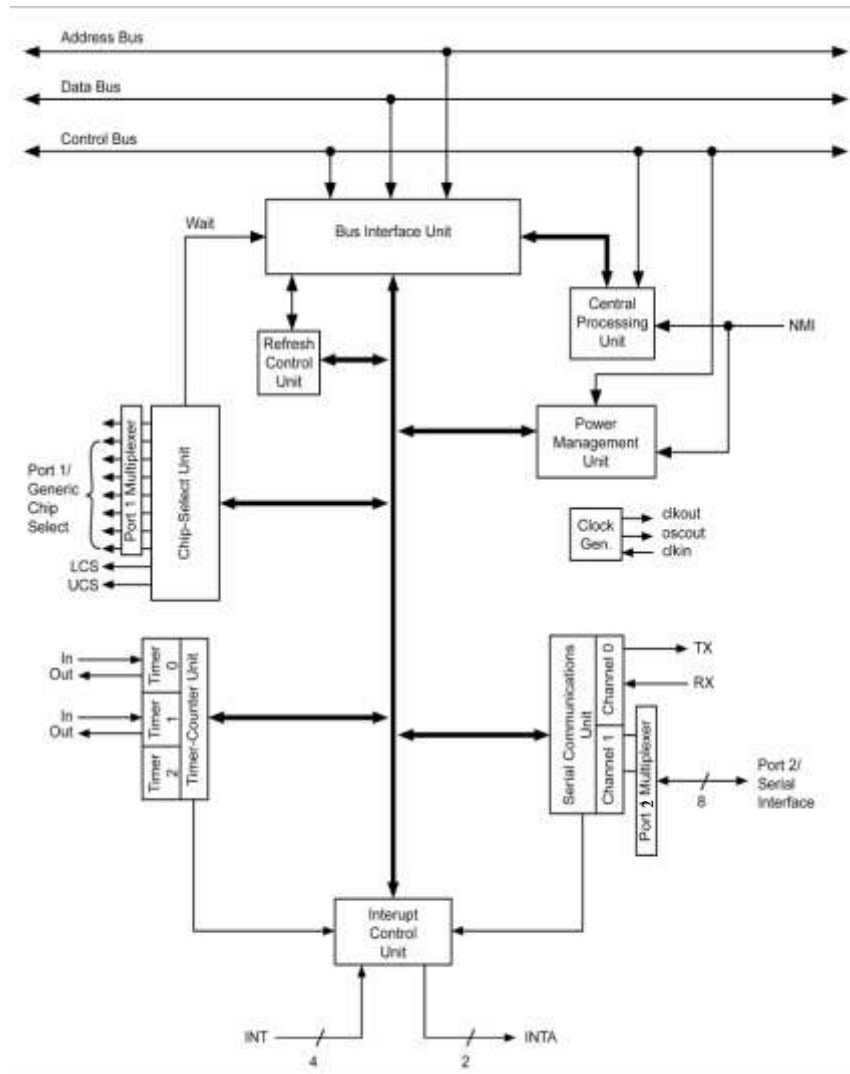

Figure 10. IA186EB/IA188EB Functional Block Diagram

4.1.2 Clock Generator

The IA186EB/IA188EB uses an on-chip clock generator to supply internal and external clocks. The clock generator makes use of a crystal oscillator and includes a divide-by-two counter.

Figure 11 shows the various operating modes of the clock circuit. The clock circuit can use either a parallel resonant fundamental mode crystal network (A) or a third-overtone mode crystal network (B), or it can be driven by an external clock source (C).

The following parameters are recommended when choosing a crystal:

- Temperature Range
 - Application Specific
 - ESR (Equivalent Series Resistance): 40Ω max
 - C0 (Shunt Capacitance of Crystal): 7.0 pF max
 - CL (Load Capacitance): 20 pF ± 2 pF
 - Drive Level: 1 mW max

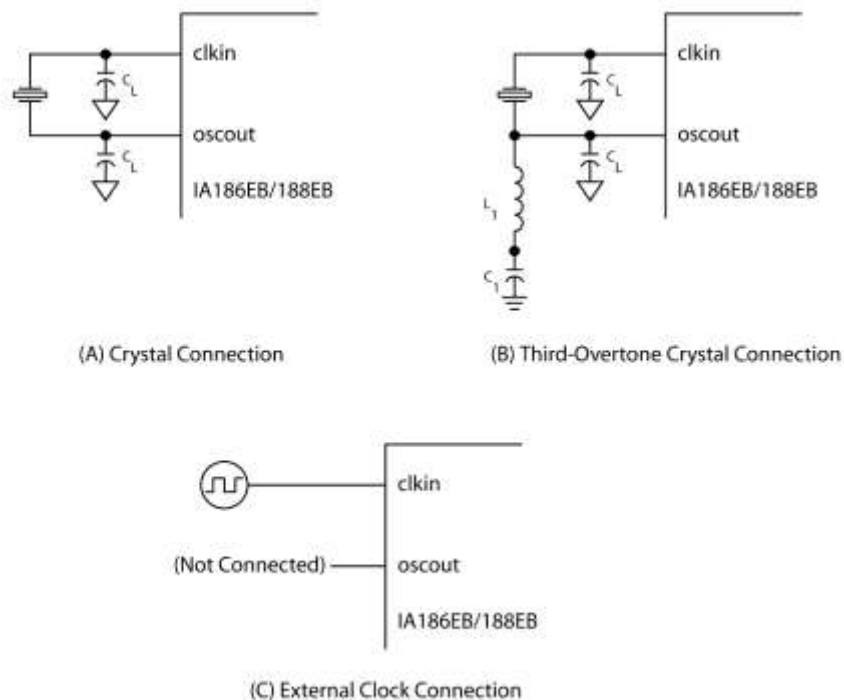

Figure 11. Clock Circuit Connection Options

4.1.3 Interrupt Control Unit

The IA186EB/IA188EB can receive interrupts from a number of sources, both internal and external. The interrupt control unit serves to merge these requests on a priority basis, for individual service by the CPU. Each interrupt source can be independently masked by the Interrupt Control Unit (ICU) or all interrupts can be globally masked by the CPU.

Internal interrupt sources include the Timers and Serial Channel 0. External interrupt sources come from the five input pins int0–int4. The NMI interrupt pin is not controlled by the ICU and is passed directly to the CPU. Although the Timer and Serial channel each have only one request input to the ICU, separate vector types are generated to service individual interrupts within the Timer and Serial channel units.

4.1.4 Timer/Counter Unit

The IA186EB/IA188EB Timer/Counter Unit (TCU) provides three 16-bit programmable timers. Two of these are highly flexible and are connected to external pins for control or clocking. A third timer is not connected to any external pins and can only be clocked internally. However, it can be used to clock the other two timer channels. The TCU can be used to count external events, time external events, generate non-repetitive waveforms, and generate timed interrupts, etc.

4.1.5 Serial Communications Unit

The Serial Control Unit (SCU) of the IA186EB/IA188EB contains two independent channels. Each channel is identical in operation except that only Channel 0 is supported by the integrated interrupt controller (Channel 1 has an external interrupt pin). Each channel has its own baud rate generator that is independent of the Timer/Counter Unit, and can be internally or externally clocked at up to one half the IA186EB/IA188EB operating frequency.

Independent baud rate generators are provided for each of the serial channels. For the asynchronous modes, the generator supplies an 8x baud clock to both the receive and transmit register logic. A 1x baud clock is provided in the synchronous mode.

4.1.6 Chip-Select Unit

The IA186EB/IA188EB Chip-Select Unit (CSU) integrates logic that provides up to ten programmable chip-selects to access both memories and peripherals. In addition, each chip select can be programmed to automatically insert additional clocks (wait-states) into the current bus cycle and automatically terminate a bus cycle independent of the condition of the ready input pin.

4.1.7 I/O Port Unit

The I/O Port Unit (IPU) on the IA186EB/IA188EB supports two 8-bit channels of input, output, or input/output operation. Port 1 is multiplexed with the chip select pins and is output only. Most of Port 2 is multiplexed with the serial channel pins.

4.1.8 Refresh Control Unit

The Refresh Control Unit (RCU) automatically generates a periodic memory read bus cycle to keep dynamic or pseudo-static memory refreshed. A 9-bit counter controls the number of clocks between refresh requests.

A 12-bit address generator is maintained by the RCU and is presented on the a1–a12 address lines during the refresh bus cycle. Address Bits [a13–a19] are programmable to allow the refresh address block to be located on any 8-Kbyte boundary.

4.1.9 Power Management Unit

The IA186EB/IA188EB Power Management Unit (PMU) is provided to control the power consumption of the device. The PMU provides three power modes: Active, Idle, and Powerdown.

Active Mode indicates that all units on the IA186EB/IA188EB are functional and the device consumes maximum power (depending on the level of peripheral operation). Idle Mode freezes the clocks of the execution and bus units at a logic zero state (all peripherals continue to operate normally).

The Powerdown mode freezes all internal clocks at a logic zero level and disables the crystal oscillator. All internal registers hold their values provided V_{CC} is maintained. Current consumption is reduced to just transistor junction leakage.

4.2 Peripheral Architecture

The IA186EB/IA188EB has integrated several common system peripherals with a CPU core to create a compact, yet powerful system. The integrated peripherals are designed to be flexible and provide logical interconnections between supporting units (e.g., the interrupt control unit supports interrupt requests from the timer/counters or serial channels). The list of integrated peripherals includes:

- 7-Input Interrupt Control Unit
- 3-Channel Timer/Counter Unit
- 2-Channel Serial Communications Unit
- 10-Output Chip-Select Unit
- I/O Port Unit
- Refresh Control Unit

- Power Management Unit

The registers associated with each integrated peripheral are contained within a 128 × 16 register file called the Peripheral Control Block (PCB). The PCB can be located in either memory or I/O space on any 256-byte address boundary.

Table 12 provides a list of the registers associated with the PCB.

Table 12. Peripheral Control Block Registers

PCB Offset	Function	PCB Offset	Function	PCB Offset	Function	PCB Offset	Function
00H	Reserved	40H	Timer2 Count	80H	GCS0 Start	C0H	Reserved
02H	End Of Interrupt	42H	Timer2 Compare	82H	GCS0 Stop	C2H	Reserved
04H	Poll	44H	Reserved	84H	GCS1 Start	C4H	Reserved
06H	Poll Status	46H	Timer2 Control	86H	GCS1 Stop	C6H	Reserved
08H	Interrupt Mask	48H	Reserved	88H	GCS2 Start	C8H	Reserved
0AH	Priority Mask	4AH	Reserved	8AH	GCS2 Stop	CAH	Reserved
0CH	In-Service	4CH	Reserved	8CH	GCS3 Start	CCH	Reserved
0EH	Interrupt Request	4EH	Reserved	8EH	GCS3 Stop	CEH	Reserved
10H	Interrupt Status	50H	Port 1 Direction	90H	GCS4 Start	D0H	Reserved
12H	Timer Control	52H	Port 1 Pin	92H	GCS4 Stop	D2H	Reserved
14H	Serial Control	54H	Port 1 Control	94H	GCS5 Start	D4H	Reserved
16H	INT4 Control	56H	Port 1 Latch	96H	GCS5 Stop	D6H	Reserved
18H	INT0 Control	58H	Port 2 Direction	98H	GCS6 Start	D8H	Reserved
1AH	INT1 Control	5AH	Port 2 Pin	9AH	GCS6 Stop	DAH	Reserved
1CH	INT2 Control	5CH	Port 2 Control	9CH	GCS7 Start	DCH	Reserved
1EH	INT3 Control	5EH	Port 2 Latch	9EH	GCS7 Stop	DEH	Reserved

Table 12. Peripheral Control Block Registers (Continued)

PCB Offset	Function	PCB Offset	Function	PCB Offset	Function	PCB Offset	Function
20H	Reserved	60H	Serial0 Baud	A0H	LCS Start	E0H	Reserved
22H	Reserved	62H	Serial0 Count	A2H	LCS Stop	E2H	Reserved
PCB Offset	Offset	PCB Offset	Function	PCB Offset	Function	PCB Offset	Function
24H	Reserved	64H	Serial0 Control	A4H	UCS Start	E4H	Reserved
26H	Reserved	66H	Serial0 Status	A6H	UCS Stop	E6H	Reserved
28H	Reserved	68H	Serial0 RBUF	A8H	Relocation	E8H	Reserved
2AH	Reserved	6AH	Serial0 TBUF	AAH	Reserved	EAH	Reserved
2CH	Reserved	6CH	Reserved	ACH	Reserved	ECH	Reserved
2EH	Reserved	6EH	Reserved	AEH	Reserved	EEH	Reserved
30H	Timer0 Count	70H	Serial1 Baud	B0H	Refresh Base	F0H	Reserved
32H	Timer0 Compare A	72H	Serial1 Count	B2H	Refresh Time	F2H	Reserved
34H	Timer0 Compare B	74H	Serial1 Control	B4H	Refresh Control	F4H	Reserved
36H	Timer0 Control	76H	Serial1 Status	B6H	Refresh Address	F6H	Reserved
38H	Timer1 Count	78H	Serial1 RBUF	B8H	Power Control	F8H	Reserved
3AH	Timer1 Compare A	7AH	Serial1 TBUF	BAH	Reserved	FAH	Reserved
3CH	Timer1 Compare B	7CH	Reserved	BCH	Step ID ¹	FCH	Reserved
3EH	Timer1 Control	7EH	Reserved	BEH	Reserved	FEH	Reserved

Note:

¹The **Step ID** register (offset 0xBC) for Revision 2 of the Innovasic device is read-only, and is uniquely identified in software by having a value of 0x0080. The original Intel device established a value between 0x0000 and 0x0002, depending on the revision of the part.

4.3 Reference Documents

Additional information on the operation and programming of the 80C186EB/80C188EB can be found in the following Intel publications:

- 80C186EB/80C188EB and 80L186EB/80L188EB 16-Bit High-Integration Embedded Processors (272433-006)
- 80C186EB/80C188EB Microprocessor User's Manual (270830-00n)

5. AC Specifications

This chapter defines the AC specifications of the IA186EB/IA188EB. Input characteristics are provided in Figure 12 and Tables 13 and 14. Output characteristics are provided in Figure 13 and Tables 15 and 16. Relative timing characteristics are provided in Figure 14 and Table 17. Clock input and clock output timing characteristics are provided in Figure 18 and Tables 18 and 19. Additional timing information is provided in [Chapter 7, Bus Timing](#), and [Chapter 8, Instruction Execution Times](#).

The following test conditions were used to derive the values in Tables 13 – 16: Rev. 0 was tested at 100C and 4.75V; Rev. 2 was tested at 100C and 4.5V.

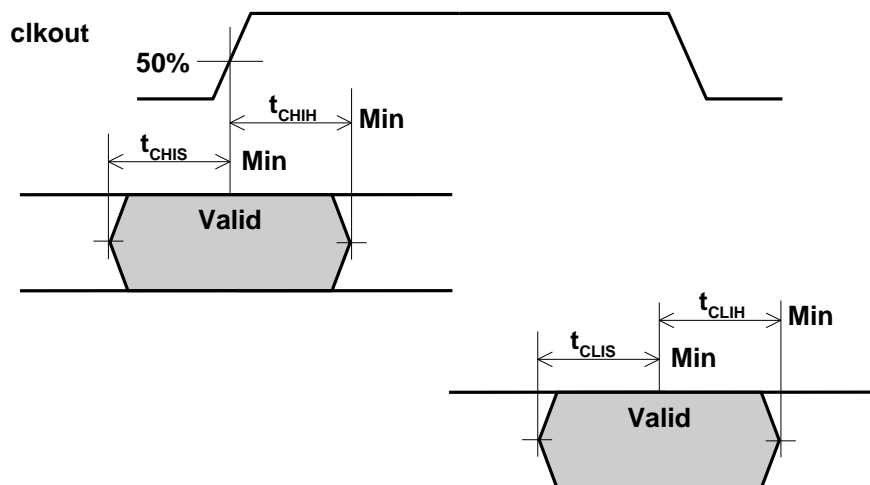

Figure 12. AC Input Characteristics

For specific 5.0- and 3.3-volt characteristics, refer to Tables 13 and 14, respectively.

Table 13. AC Input Characteristics for 5.0-Volt Operation

Symbol	Pins	Min	Max	Units
t_{CHIS}	test_n, nmi, int4-int0, bclk1-bclk0, t1in-t0in, ready, cts1_n-cts0_n, p2.6, p2.7	10	-	ns
t_{CHIH}	test_n, nmi, int4-int0, bclk1-bclk0, t1in-t0in, ready, cts1_n-cts0_n	3	-	ns
t_{CLIS}	ad15-ad0, ad7-ad0 (IA188EB), ready	10	-	ns
t_{CLIS}	hold, pereq, error_n	10	-	ns
t_{CLIH}	ad15-ad0, ad7-ad0 (IA188EB), ready	3	-	ns
t_{CLIH}	hold, pereq, error_n	3	-	ns

Table 14. AC Input Characteristics for 3.3-Volt Operation

Symbol	Pins	Min	Max	Units
t_{CHIS}	test_n, nmi, int4-int0, bclk1-bclk0, t1in-t0in, ready, cts1_n-cts0_n, p2.6, p2.7	10	-	ns
t_{CHIH}	test_n, nmi, int4-int0, bclk1-bclk0, t1in-t0in, ready, cts1_n-cts0_n	3	-	ns
t_{CLIS}	ad15-ad0, ad7-ad0 (IA188EB), ready	10	-	ns
t_{CLIS}	hold, pereq, error_n	10	-	ns
t_{CLIH}	ad15-ad0, ad7-ad0 (IA188EB), ready	3	-	ns
t_{CLIH}	hold, pereq, error_n	3	-	ns

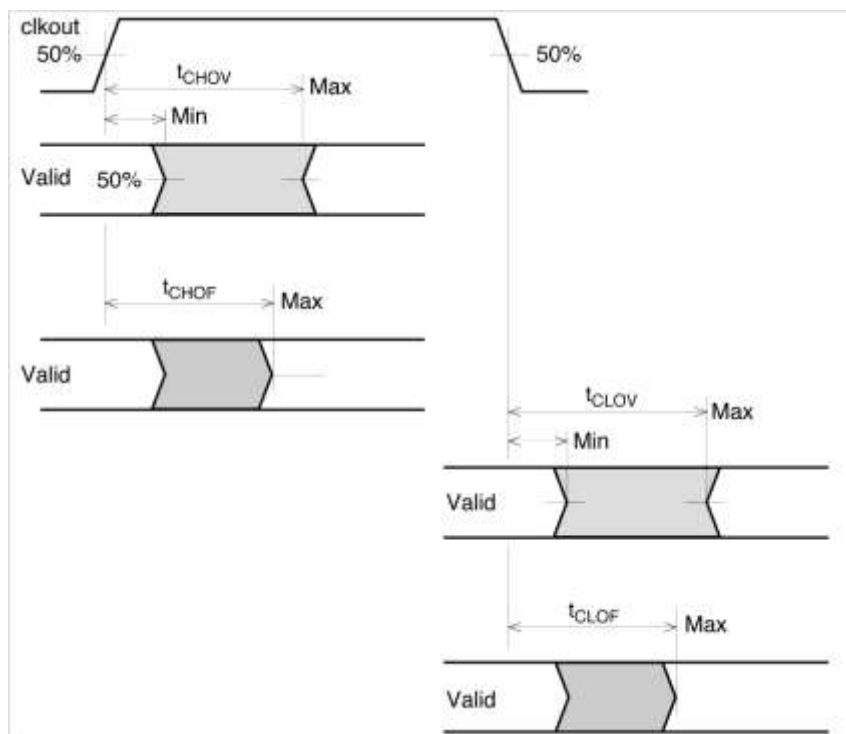

Figure 13. AC Output Characteristics

For specific 5.0- and 3.3-volt characteristics, refer to Tables 15 and 16, respectively.

Table 15. AC Output Characteristics for 5.0-Volt Operation

Symbol	Parameter	Min	Max	Units
t _{CHOV}	ale, s2-s0_n, den_n, dt/r_n, bhe_n, rfsh_n (IA188EB), lock_n, a19-a16	3	17	ns
	gcs0-gcs7_n, lcs_n, ucs_n, ncs_n, rd_n, wr_n	3	20	ns
t _{CLOV}	bhe_n, rfsh_n (IA188EB), den_n, lock_n, resout, hlda, t0out, t1out, a19-a16	3	17	ns
	rd_n, wr_n, gcs7-gcs0_n, lcs_n, ucs_n, ad15-ad0, ad7-ad0 (IA188EB), a15-a8 (IA188EB), ncs_n, inta1_n-inta0_n, s2_n-s0_n	3	20	ns
t _{CHOF}	re_n, wr_n, bhe_n, rfsh_n (IA188EB), dt/r_n, lock_n, s2_n-s0_n, a19-a16	0	20	ns
t _{CLOF}	den_n, ad15-ad0, ad7-ad0 (IA188EB), a15-a8 (IA188EB)	0	20	ns

Table 16. AC Output Characteristics for 3.3-Volt Operation

Symbol	Parameter	Min	Max	Units
t _{CHOV}	ale, s2-s0_n, den_n, dt/r_n, bhe_n, rfsh_n (IA188EB), lock_n, a19-a16	3	25	ns
	gcs0-gcs7_n, lcs_n, ucs_n, ncs_n, rd_n, wr_n	3	30	ns
t _{CLOV}	bhe_n, rfsh_n (IA188EB), den_n, lock_n, resout, hlda, t0out, t1out, a19-a16	3	25	ns
	rd_n, wr_n, gcs7-gcs0_n, lcs_n, ucs_n, ad15-ad0, ad7-ad0 (IA188EB), a15-a8 (IA188EB), ncs_n, inta1_n-inta0_n, s2_n-s0_n	3	30	ns
t _{CHOF}	re_n, wr_n, bhe_n, rfsh_n (IA188EB), dt/r_n, lock_n, s2_n-s0_n, a19-a16	0	30	ns
t _{CLOF}	den_n, ad15-ad0, ad7-ad0 (IA188EB), a15-a8 (IA188EB)	0	30	ns

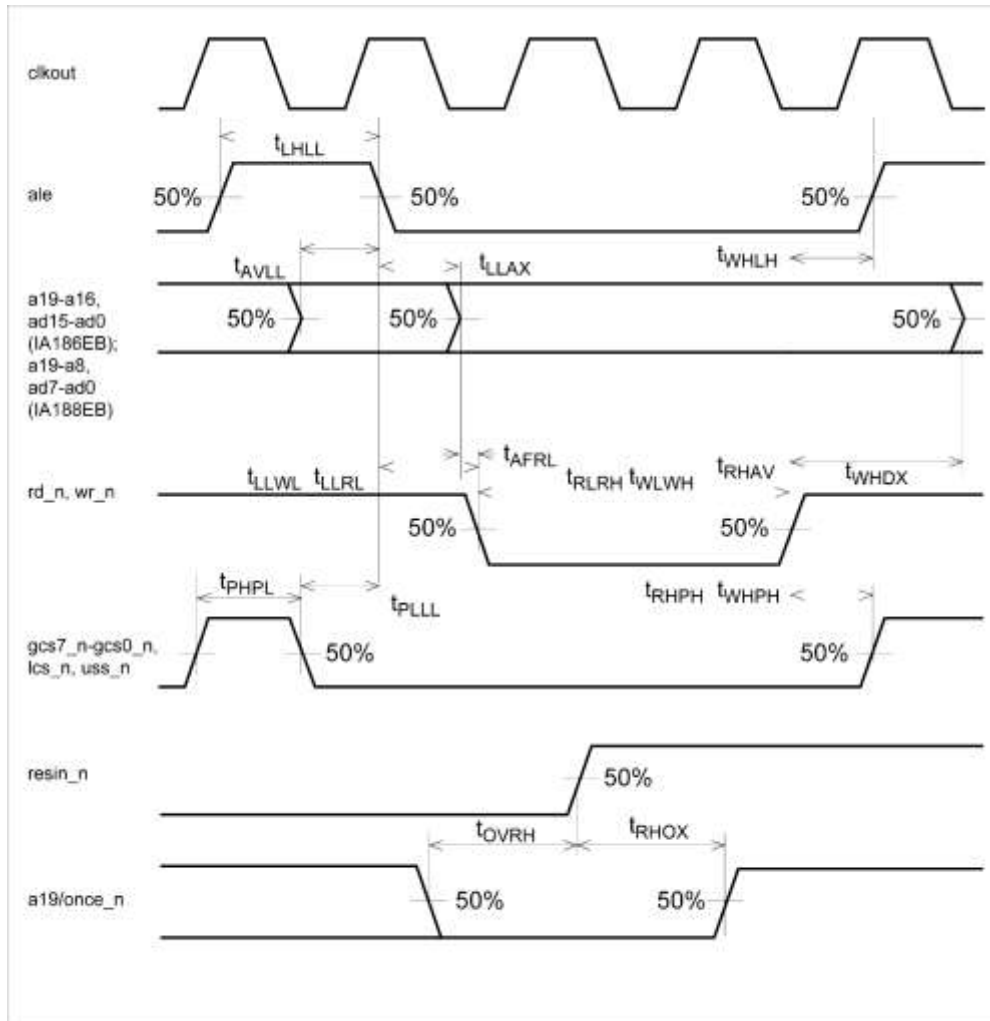

Figure 14. Relative Timing Characteristics

For specific relative timing characteristics, refer to Table 17.

Table 17. Relative Timing Characteristics

Symbol	Parameter	Min	Max	Units
t_{LHLL}	ale Rising to ale Falling	$t - 15$	–	ns
t_{AVLL}	Address Valid to ale Falling	$\frac{1}{2}t - 10$	–	ns
t_{PLLL}	Chip Selects Valid to ale Falling	$\frac{1}{2}t - 10$	–	ns
t_{LLAX}	Address Hold from ale Falling	$\frac{1}{2}t - 10$	–	ns
t_{LLWL}	ale Falling to wr_n Falling	$\frac{1}{2}t - 15$	–	ns
t_{LLRL}	ale Falling to rd_n Falling	$\frac{1}{2}t - 15$	–	ns
t_{WHLH}	wr_n Rising to ale Rising	$\frac{1}{2}t - 10$	–	ns
t_{AFRL}	Address Float to rd_n Falling	0	–	ns
t_{RLRH}	rd_n Falling to rd_n Rising	$(2t) - 5$	–	ns
t_{WLWH}	wr_n Falling to wr_n Rising	$(2t) - 5$	–	ns
t_{RHAV}	rd_n Rising to Address Active	$t - 15$	–	ns
t_{WHDX}	Output Data Hold after wr_n Rising	$t - 15$	–	ns
t_{WHPH}	wr_n Rising to Chip Select Rising	$\frac{1}{2}t - 10$	–	ns
t_{RHPH}	rd_n Rising to Chip Select Rising	$\frac{1}{2}t - 10$	–	ns
t_{PHPL}	cs_n inactive to cs_n active	$\frac{1}{2}t - 10$	–	ns
t_{OVRH}	once_n Active to resin_n Rising	t	–	ns
t_{RHOX}	once_n Hold to resin_n Rising	t	–	Ns

5.1 AC Test Conditions

The AC specifications are tested with the 50-pF load shown in Figure 15. Specifications are measured at the $V_{CC}/2$ crossing point unless otherwise specified.

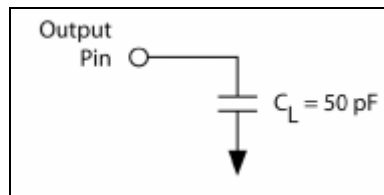

Figure 15. AC Test Load

5.2 Clock Input and Clock Output Timing Characteristics

For clock input and clock output timing characteristics for both 5.0- and 3.3-volt operation, see Tables 18 and 19, respectively.

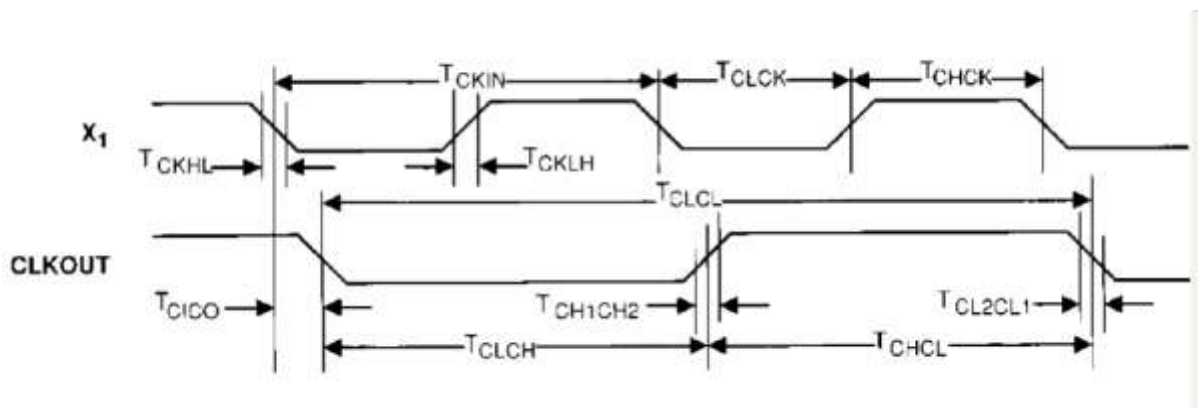

Figure 16. Clock Input and Clock Output Timing Characteristics

Table 18. Clock Input and Clock Output Timing Characteristics for 5.0-Volt Operation

Item	Symbol	Parameter	Min	Max	Units	Notes
–	XTF	ckin Frequency	0	50	MHz	–
1	TCKIN	ckin Period	20	∞	ns	–
2	TCHCK	ckin High Time	10	∞	ns	Measure for VIH for high time, NIL for low time.
3	TCLCK	ckin Low Time	10	∞	ns	Measure for VIH for high time, NIL for low time.
4	TCKLH	ckin Rise Time	1	5	ns	Only required to guarantee ICC. Maximum limits are bounded for TC, TCH, and TCL.
5	TCKHL	ckin Fall Time	1	5	ns	Only required to guarantee ICC. Maximum limits are bounded for TC, TCH, and TCL.
6	TCICO	ckin to clkout Delay	0	11.5	ns	Specified for a 50-pF load.
7	TCLCL	clkout Period	–	2TCKIN	ns	–
8	TCHCL	clkout High Time	(TCLCL/2) – 5	(TCLCL/2) + 5	ns	Measure for VIH for high time, NIL for low time.
9	TCCCH	clkout Low Time	(TCLCL/2) – 5	(TCLCL/2) + 5	ns	Measure for VIH for high time, NIL for low time.
10	TCH1CH2	clkout Rise Time	1	6	ns	Specified for a 50-pF load.
11	TCL2CL1	clkout Fall Time	1	6	ns	Specified for a 50-pF load.

Table 19. Clock Input and Output Characteristics for 3.3-Volt Operation

Item	Symbol	Parameter	Min	Max	Units	Notes
–	XTF	clk _{in} Frequency	0	32	MHz	–
1	TC	clk _{in} Period	30	∞	ns	–
2	TCH	clk _{in} High Time	15	∞	ns	Measure for VIH for high time, NIL for low time.
3	TCL	clk _{in} Low Time	15	∞	ns	Measure for VIH for high time, NIL for low time.
4	TCR	clk _{in} Rise Time	1	5	ns	Only required to guarantee ICC. Maximum limits are bounded for TC, TCH and TCL.
5	TCF	clk _{in} Fall Time	1	5	ns	Only required to guarantee ICC. Maximum limits are bounded for TC, TCH and TCL.
6	XTCD	clk _{in} to clk _{out} Delay	0	14.5	ns	Specified for a 50-pF load.
7	T	clk _{out} Period	–	2TC	ns	–
8	TPH	clk _{out} High Time	(T/2) – 5	(T/2) + 5	ns	Measure for VIH for high time, NIL for low time.
9	TPL	clk _{out} Low Time	(T/2) – 5	(T/2) + 5	ns	Measure for VIH for high time, NIL for low time.
10	TPR	clk _{out} Rise Time	1	6	ns	Specified for a 50-pF load.
11	TPF	clk _{out} Fall Time	1	6	ns	Specified for a 50-pF load.

5.3 Serial Port Mode 0 Timing Characteristics

Serial Port Mode 0 timing characteristics are illustrated in Figure 17 and collected in Table 20.

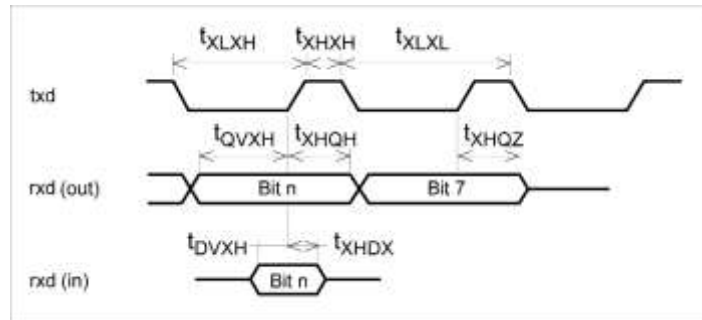

Figure 17. Serial Port Mode 0 Timing Characteristics

Table 20. Serial Port Mode 0 Timing Characteristics

Symbol	Parameter	Minimum	Maximum	Units
t_{XLXL}	txd Clock Period	$t(n+1)$	–	ns
t_{XLXH}	txd Clock Low to Clock High ($n > 1$)	$2t - 35$	$2t + 35$	ns
t_{XLXH}	txd Clock Low to Clock High ($n = 1$)	$t - 35$	$t + 35$	ns
t_{XHXL}	txd Clock High to Clock Low ($n > 1$)	$(n-1)t - 35$	$(n-1)t + 35$	ns
t_{XHXL}	txd Clock High to Clock Low ($n = 1$)	$t - 35$	$t + 35$	ns
t_{QVXH}	rxid Output Data Setup to txd Clock High ($n > 1$)	$(n-1)t - 35$	–	ns
t_{QVXH}	rxid Output Data Setup to txd Clock High ($n = 1$)	$t - 35$	–	ns
t_{XHQX}	rxid Output Data Hold after txd Clock High ($n > 1$)	$2t - 35$	–	ns
t_{XHQX}	rxid Output Data Hold after txd Clock High ($n = 1$)	$t - 35$	–	ns
t_{XHQZ}	rxid Output Data Float after Last txd Clock High	–	$t + 20$	ns
t_{DVXH}	rxid Input Data Setup to txd Clock High	$t + 20$	–	ns
t_{XHDX}	rxid Input Data Hold after txd Clock High	0	–	ns

6. Reset Operation

The IA186EB/IA188EB will perform a reset operation any time the resin_n pin is active. Figure 18 shows the reset sequence when power is applied to the IA186EB/IA188EB. An external clock connected to clk_{in} must not exceed the V_{CC} threshold being applied to the processor. This is normally not a problem if the clock driver is supplied with the same V_{CC} that supplies the processor. When attaching a crystal to the device, resin_n must remain active until both V_{CC} and clk_{out} are stable (the length of time is application-specific and depends on the startup characteristics of the crystal circuit). The resin_n pin is designed to operate correctly using an RC reset circuit, but the designer must ensure that the ramp time for V_{CC} is not so long that resin_n is never really sampled at a logic low level when V_{CC} reaches minimum operating conditions.

Note: Failure to assert resin_n while the device is powering up will result in unpredictable operation.

Figure 19, Warm Reset Timing, shows the timing sequence when resin_n is applied after V_{CC} is stable and the device has been operating. Any bus operation that is in progress at the time resin_n is asserted will terminate immediately.

While resin_n is active, bus signals lock_n, a19/once_n, and a18–a16 are configured as inputs and weakly held high by internal pull-up transistors. Only a19/once_n can be overdriven to a low-to-enable ONCE Mode.

7. Bus Timing

Figures 18 through 26 on the following pages present the various bus cycles that are generated by the processor. The figures show the relationship of the various bus signals to clk_{out}. Together with the information present in AC Characteristics, the figures allow the user to determine all the critical timing analysis needed for a given application.

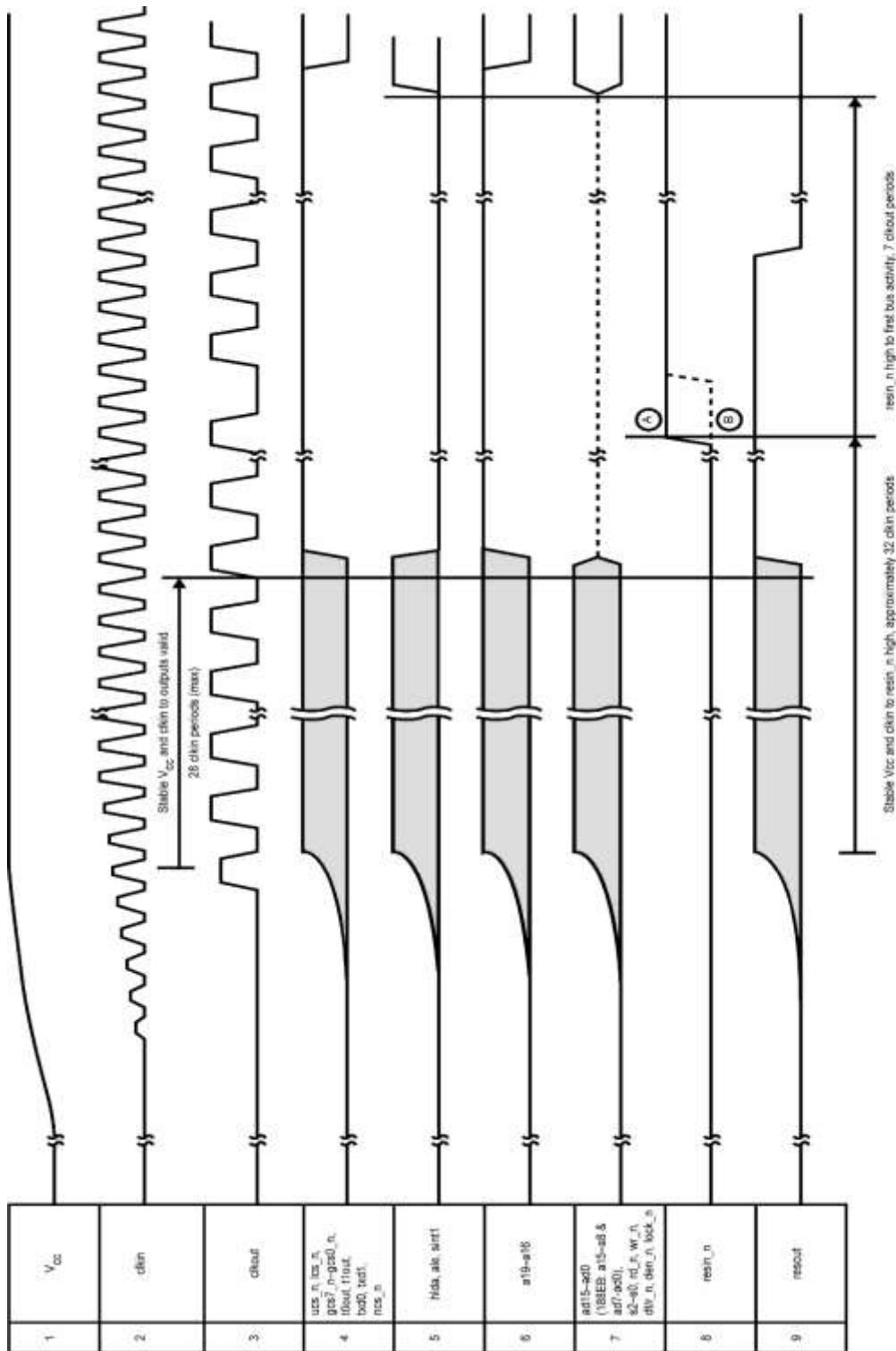
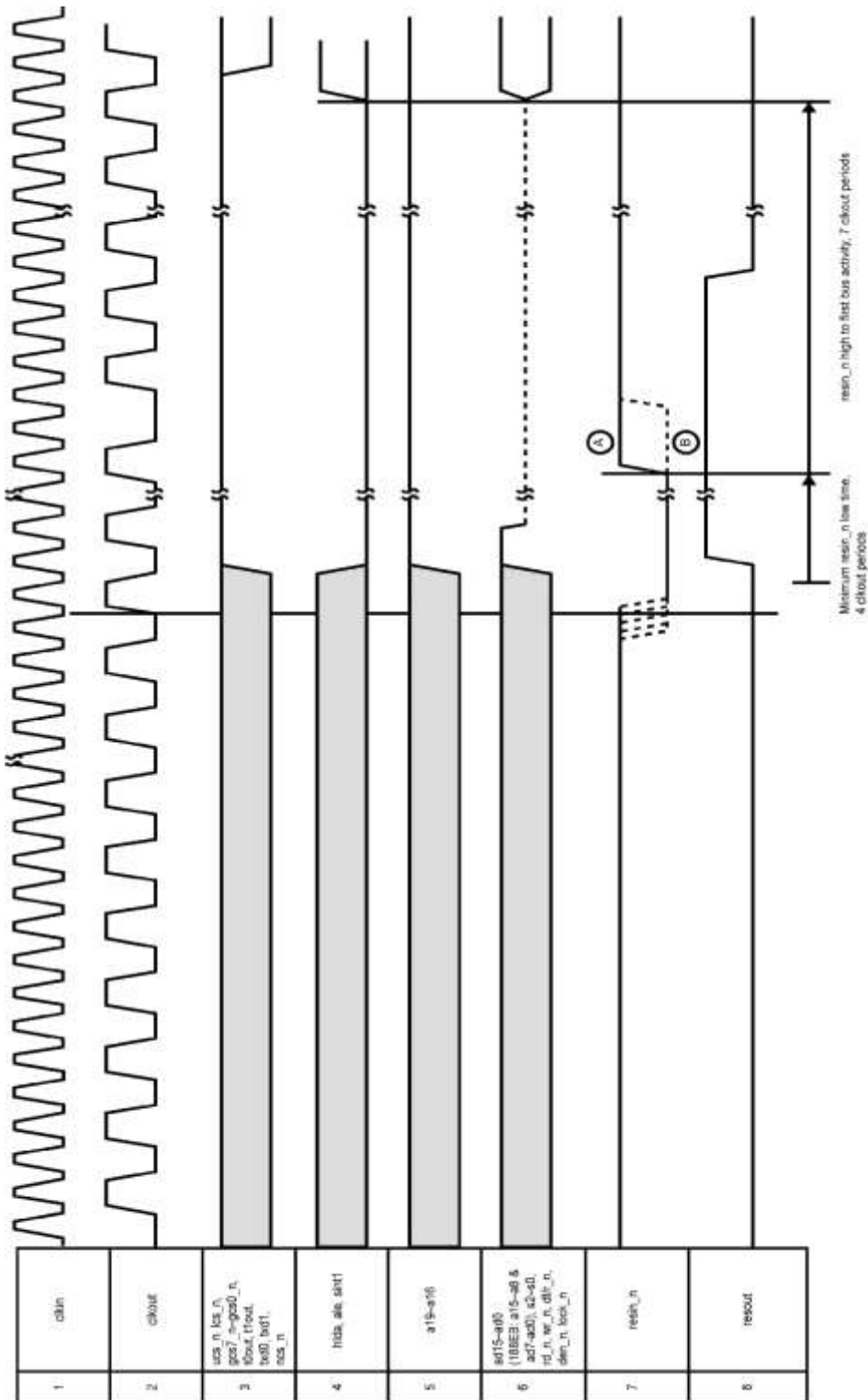

Figure 18. Cold Reset Timing

ckout synchronization occurs on the rising edge of resn_n. If resn_n is high when ckout is high (A), then ckout remains low for two clkin periods. If resn_n is high while ckout is low (B), then ckout is not affected.



clkout synchronization occurs on the rising edge of resin_n. If resin_n is high when clkout is high (A), clkout remains low for two clkIn periods. If resin_n is sampled high when clkout is low (B), clkout is not affected.

Figure 19. Warm Reset Timing

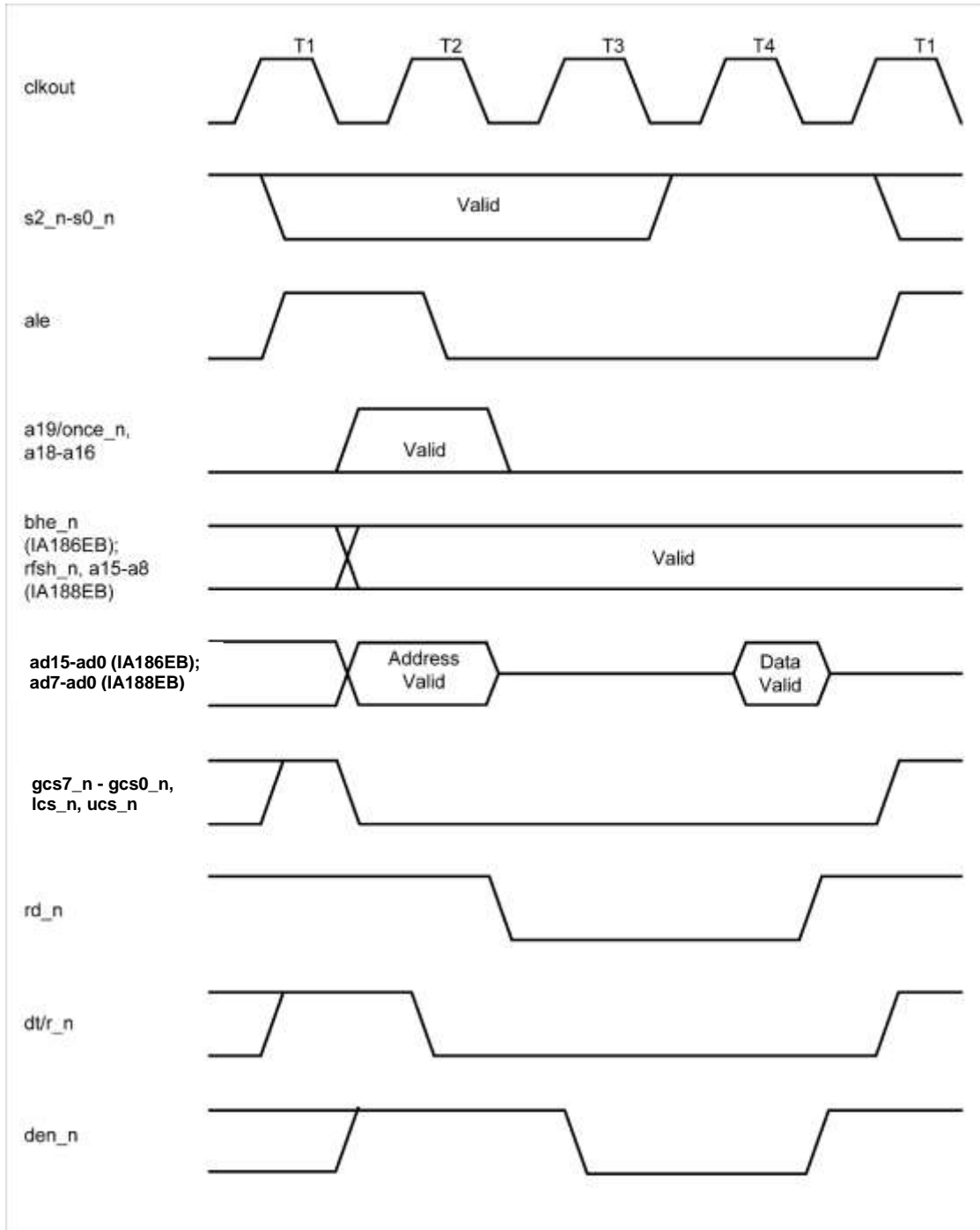

Figure 20. Read, Fetch, and Refresh Cycle Timing

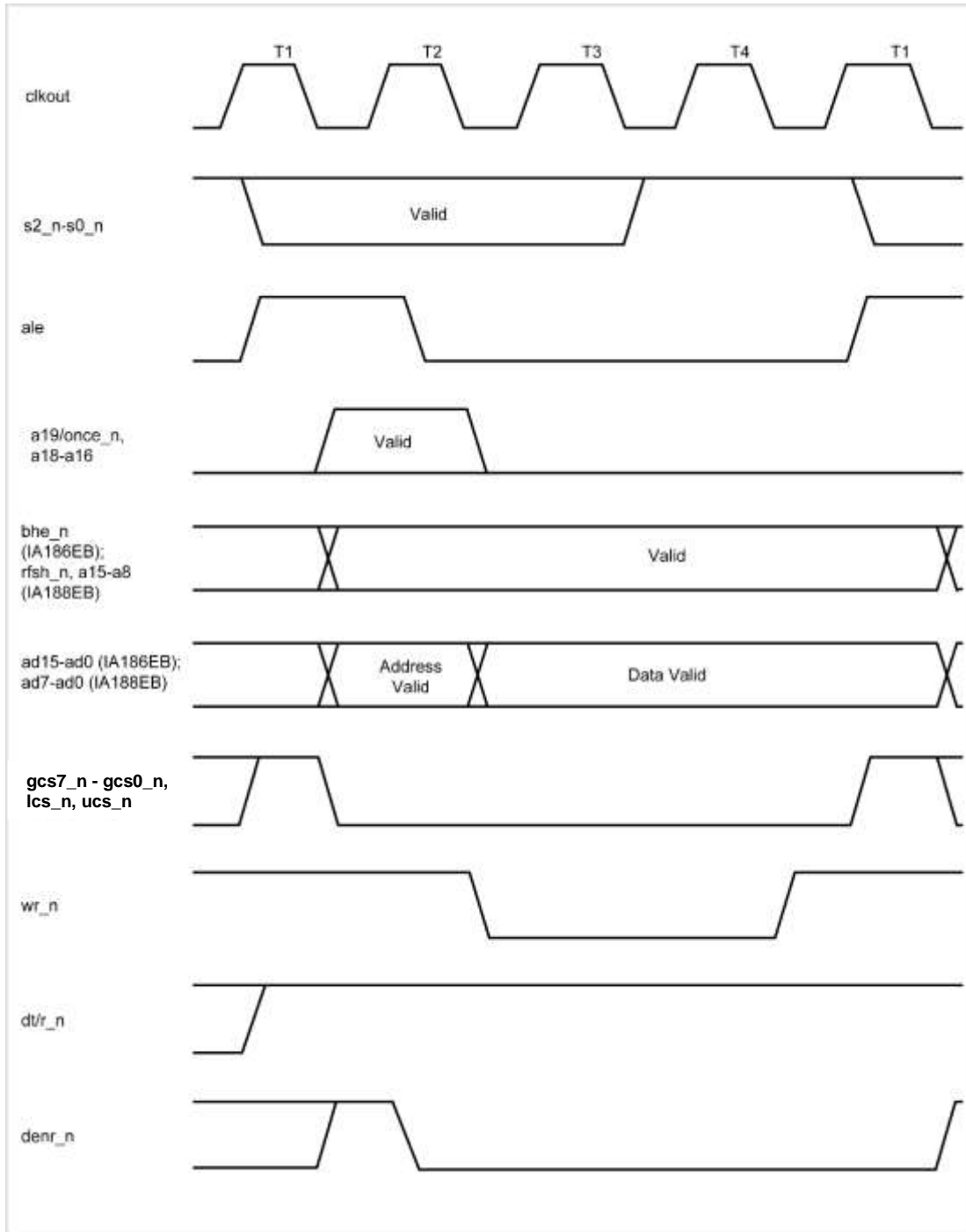

Figure 21. Write Cycle Timing

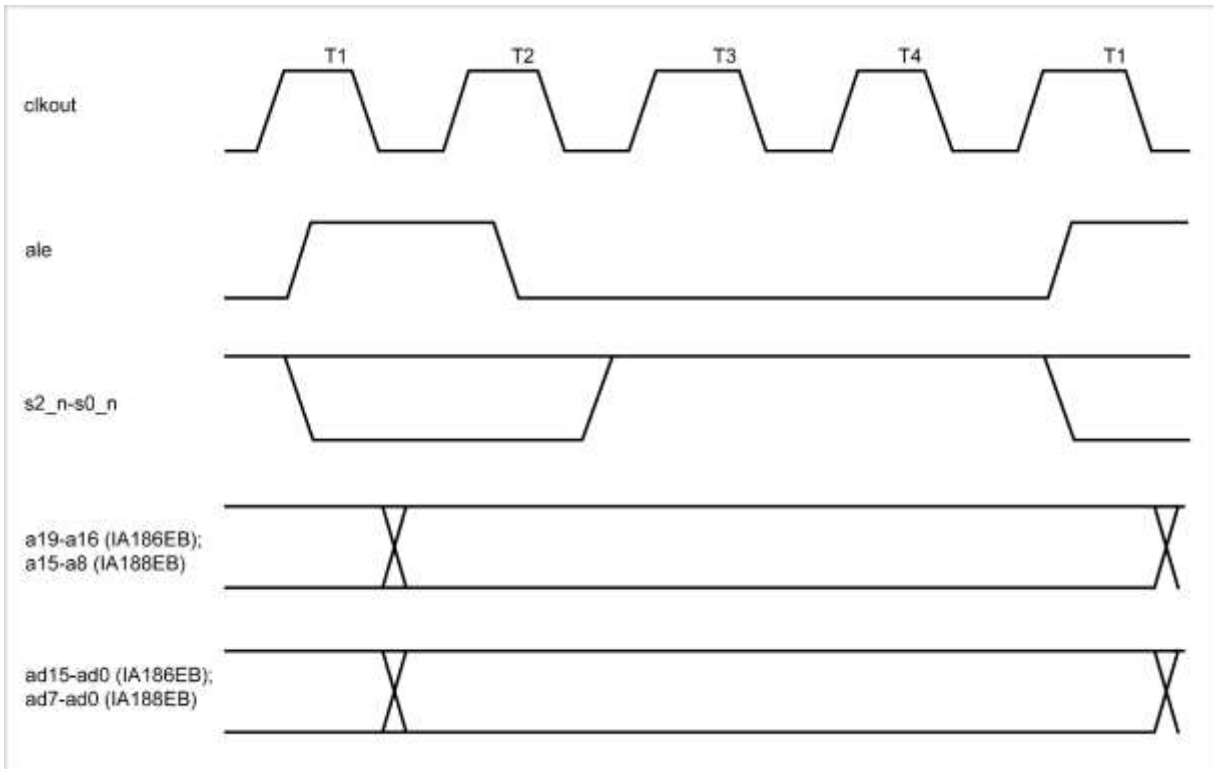

Figure 22. Halt Cycle Timing

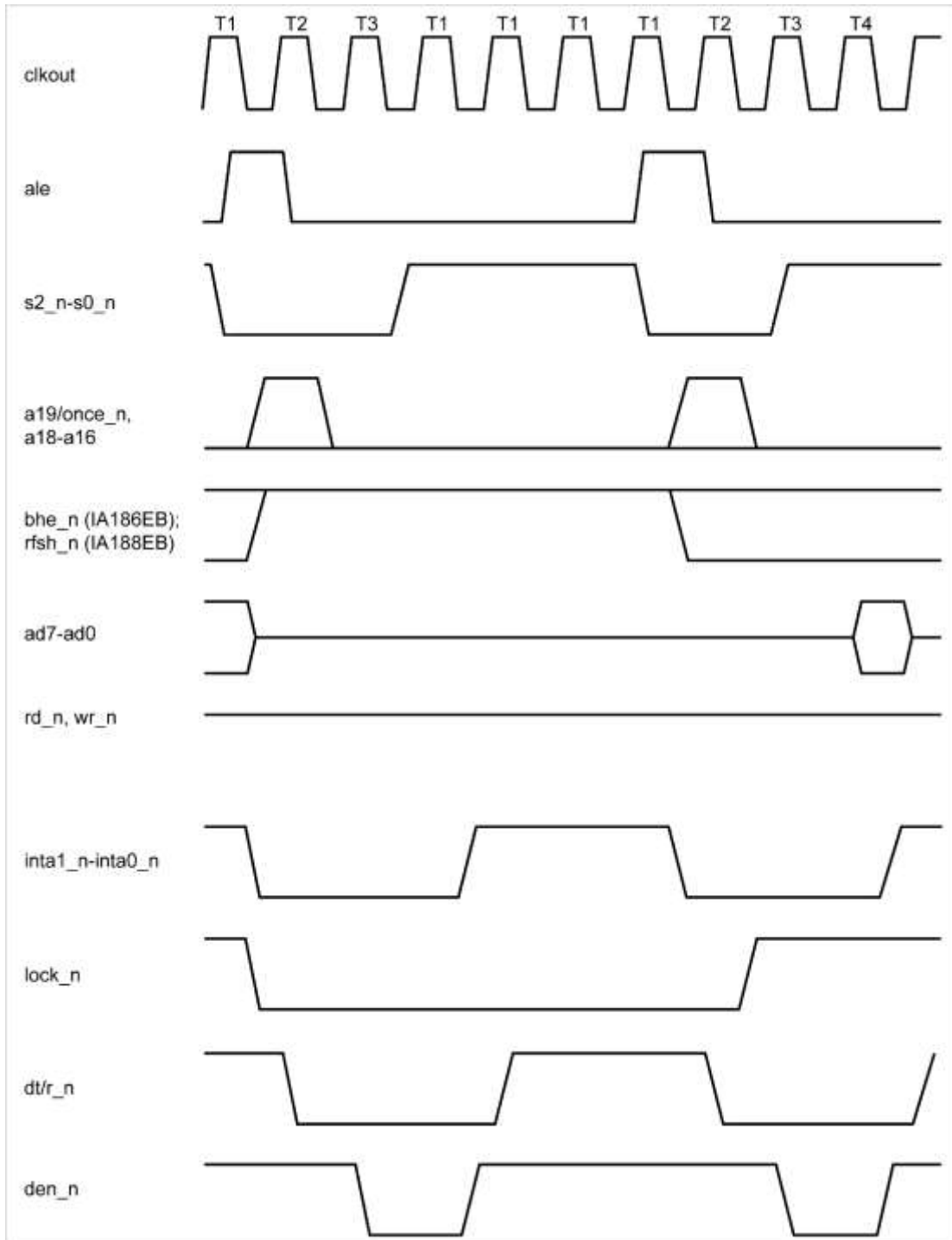

Figure 23. Interrupt Acknowledge (inta1_n, inta0_n) Cycle Timing

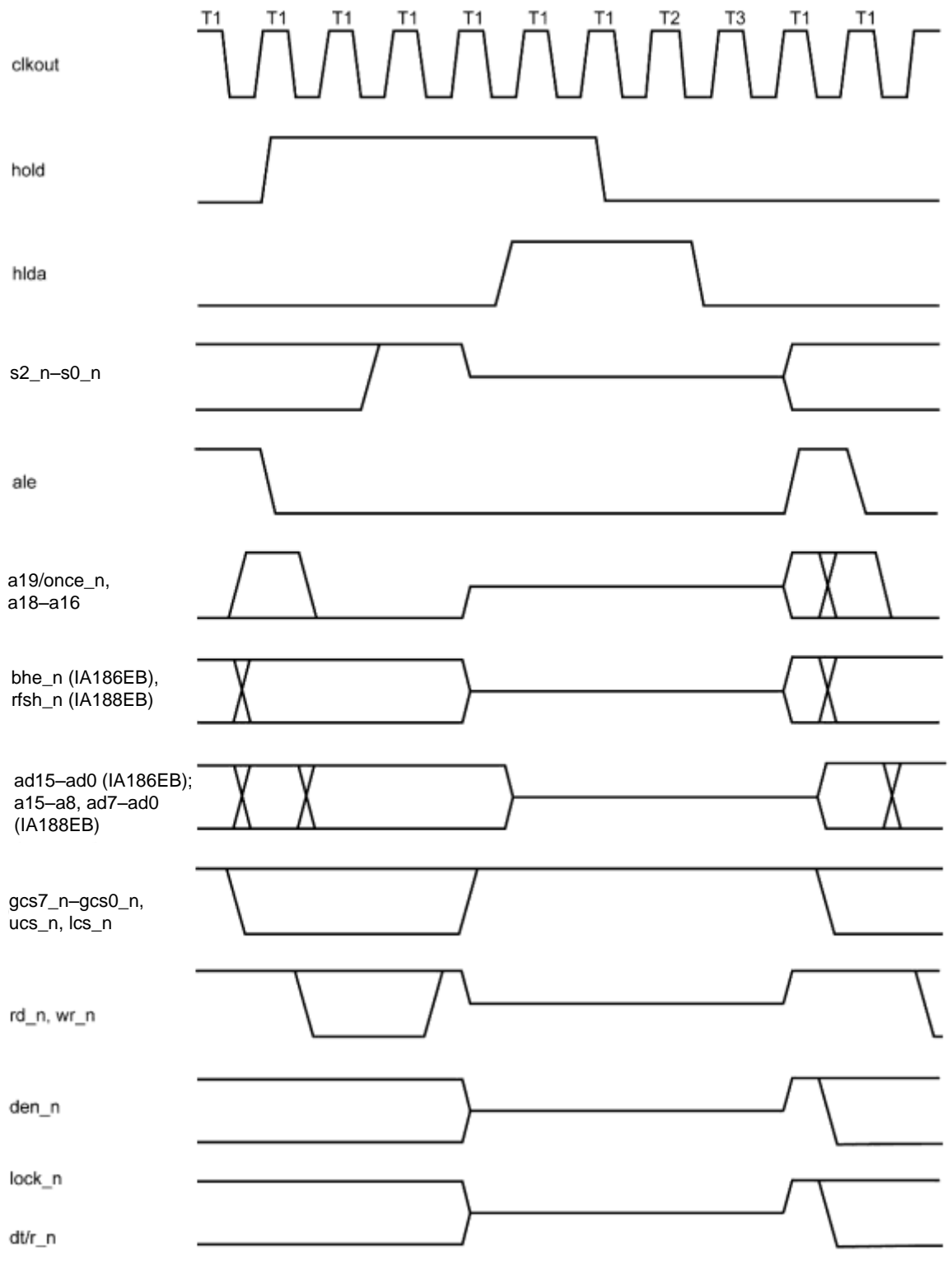

Figure 24. hold/hlda Timing

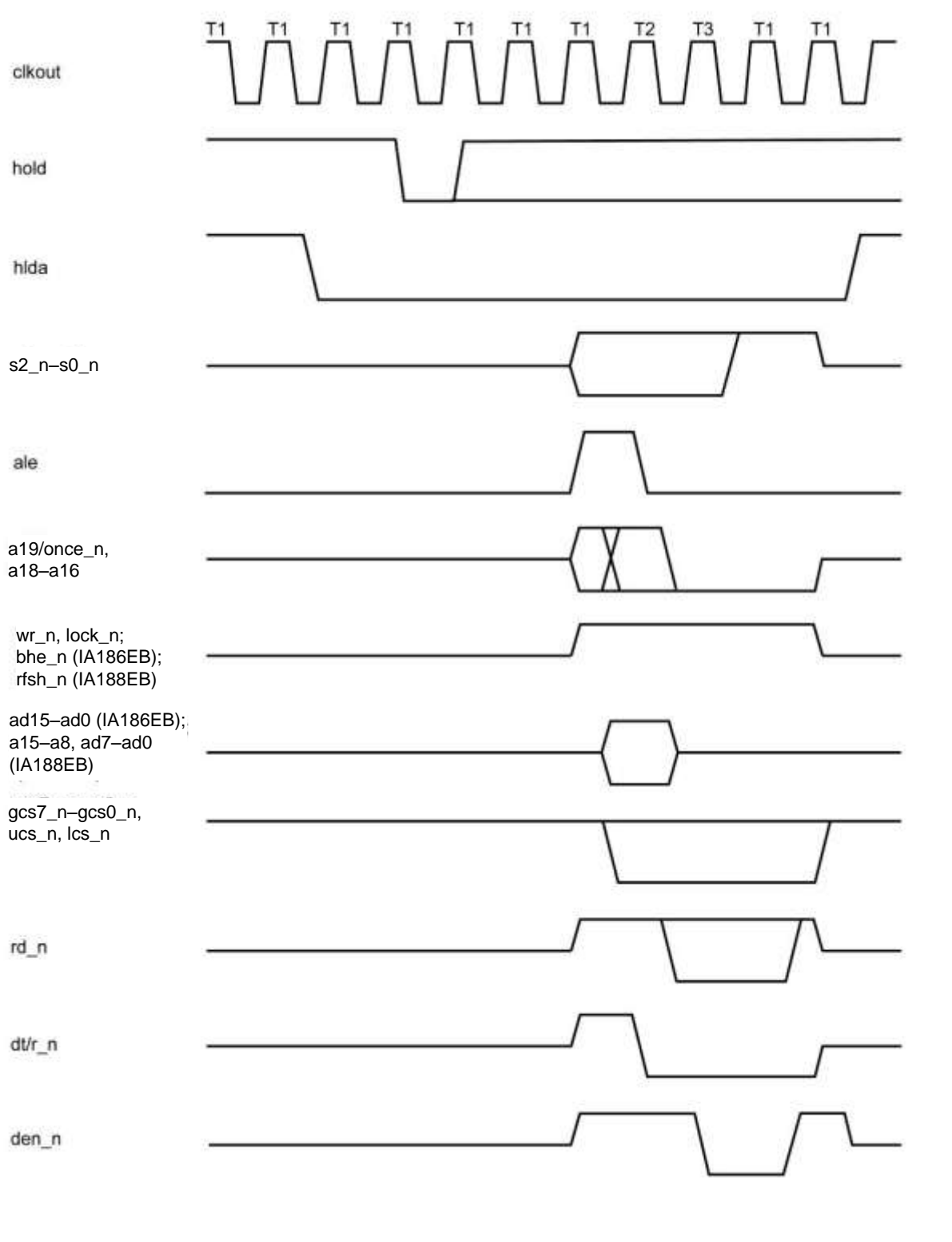

Figure 25. Refresh During Hold Acknowledge Timing

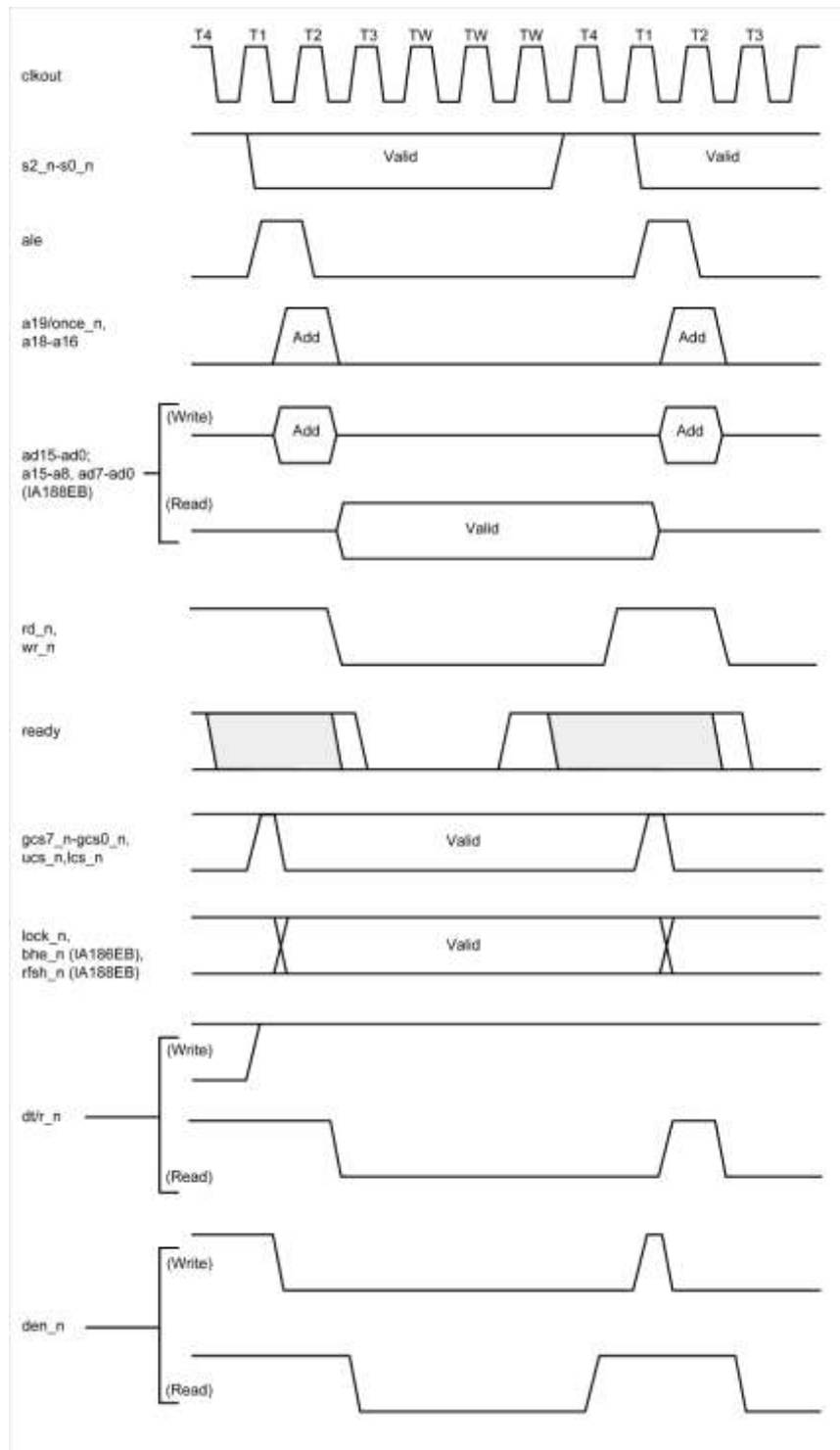

Figure 26. Ready Timing

8. Instruction Execution Times

Table 21 provides IA186EB and IA188EB execution times, mnemonic instruction, and additional information on execution, if required. The execution times apply to all versions of the parts.

Table 21. Instruction Set Timing

Instruction	Clock Cycles		Comments
	IA186EB	IA188EB	
AAA	3	3	–
AAD	6	6	–
AAM	40	40	–
AAS	3	3	–
ADC Immediate to accumulator	1	1	–
ADC Immediate to register/memory	3	13	–
ADC Register/memory with register to either	1/16	1/24	register/memory
ADD Immediate to accumulator	1	1	–
ADD Immediate to register/memory	1/19	1/32	register/memory
ADD Register/memory with register either	1/20	1/28	
AND Immediate to accumulator	1	1	–
AND Immediate to register/memory	1/24	1/33	register/memory
AND Register/memory and register to either	1/12	1/15	
BOUND	20/40	24/64	Interrupt not taken/Interrupt taken
CBW	1	4	–
CLC	1	1	–
CLD	1	1	–
CLI	1	1	–
CMC	2	2	–
CMPS	9	20	–
CS	1	1	–
CWD	1	1	–
DAA	4	4	–
DAS	2	2	–
DEC Register	1	1	–
DEC Register/memory	1/24	1/32	register/memory

Table 21. Instruction Set Timing (Continued)

Instruction	Clock Cycles		Comments
	IA186EB	IA188EB	
DIV Memory-Byte	46	46	—
DIV Memory-Word	49	51	—
DIV Register-Byte	39	39	—
DIV Register-Word	39	39	—
IDIV Memory-Byte	46	46	—
IDIV Memory-Word	49	51	—
IDIV Register-Byte	39	39	—
IDIV Register-Word	39	39	—
IMUL Immediate (signed)	5/24	5/33	register/memory
IMUL Memory-Byte	4	20	—
IMUL Memory-Word	13	28	—
IMUL Register-Byte	5	5	—
IMUL Register-Word	5	5	—
INC Register	1	1	—
INS	8	16	—
INS (repeated n times)	$8+8n$	$16+16n$	—
INT Type specified	33	41	—
INT Type 3	33	41	—
INTO	33	48	—
IRET	30	30	—
JA	3/5	3/5	Jump not taken/Jump taken
JAE	3/5	3/5	
JB	3/5	3/5	
JBE	3/5	3/5	
JCXZ	3/4	3/4	Jump not taken/Jump taken
JE	3/5	3/5	Jump not taken/Jump taken
JG	3/5	3/5	
JGE	3/5	3/5	
JL	3/5	3/5	
JLE	3/5	3/5	
JMP Direct intersegment	3	3	
JMP Direct within segment	3	3	—
JMP Short/long	4	4	—
JNA	3/5	3/5	Jump not taken/Jump taken
JNAE	3/5	3/5	
JNB	3/5	3/5	
JNBE	3/5	3/5	
JNE	3/5	3/5	
JNG	3/5	3/5	
JNGE	3/5	3/5	
JNL	3/5	3/5	
JNLE	3/5	3/5	
JNO	3/5	3/5	
JNP	3/5	3/5	

Table 21. Instruction Set Timing (Continued)

Instruction	Clock Cycles		Comments
	IA186EB	IA188EB	
JNS	3/5	3/5	Jump not taken/Jump taken
JNZ	3/5	3/5	
JO	3/5	3/5	
JP	3/5	3/5	
JPE	3/5	3/5	
JPO	3/5	3/5	
JS	3/5	3/5	
JZ	3/5	3/5	
LAHF	2	2	–
LDS	1/24	1/33	register/memory
LEA	3	3	–
LEAVE	12	12	–
LES	12	32	–
LOCK	1	1	–
LODS	8	12	–
LODS (repeated n times)	$8+8n$	$12+12n$	–
LOOP	3/4	3/4	Loop not taken/Loop taken
LOOPE	3/4	3/4	
LOOPNE	3/4	3/4	
LOOPNZ	3/4	3/4	
LOOPZ	3/4	3/4	
MOV Accumulator to memory	5	8/12	
MOV Immediate to register	1	1	–
MOV Immediate to register/memory	1/5	1/12	register/memory
MOV Memory to accumulator	5	8/12	8-bit/16-bit
MOV Register to Register/Memory	2/5	2/20	register/memory
MOV Register/memory to register	2/5	2/20	
MOV Register/memory to segment register	2/5	2/20	
MOV Segment register to register/memory	2/5	2/20	
MOVS	24	32	–
MOVS (repeated n times)	$24+24n$	$32+32n$	–
MUL Memory-Byte	16	20	–
MUL Memory-Word	15	25	–
MUL Register-Byte	5	5	–
MUL Register-Word	5	5	–
NEG	1/32	1/15	register/memory
NOP	1	1	–
NOT	1/24	1/24	register/memory
OR Immediate to accumulator	1	1	–

Table 21. Instruction Set Timing (Continued)

Instruction	Clock Cycles		Comments
	IA186EB	IA188EB	
OR Immediate to register/memory	1/32	1/32	register/memory
OR Register/memory and register to either	1/32	1/24	
OUT Fixed port	5	8/12	8-bit/16-bit
OUT Variable port	5	12	–
OUTS	8	12/20	8-bit/16-bit
OUTS (repeated n times)	$8+8n$	$12/20+12/20n$	8-bit/16-bit
POP Memory	10	20	–
POP Register	10	12	–
POP Segment register	16	12	–
POPA	80	93	–
POPF	13	13	–
PUSH Immediate	8	12	–
PUSH Memory	15	28	–
PUSH Register	4	12	–
PUSH Segment register	4	12	–
PUSHA	64	72	–
PUSHF	4	16	–
RET Inter-segment	14	21	–
RET Inter-segment adding immediate to SP	25	21	–
RET Within segment	14	13	–
RET Within segment adding immediate to SP	16	13	–
ROL Register/Memory by 1	1/8	1/16	register/memory
ROL Register/Memory by CL	1/8	1/16	
ROL Register/Memory by Count	1/8	1/24	
ROR Register/Memory by 1	1/8	1/16	
ROR Register/Memory by CL	1/8	1/16	
ROR Register/Memory by Count	1/8	1/24	
SAHF	2	2	
SBB Immediate from accumulator	1	1	–
SBB Immediate from register/memory	1/15	1/28	register/memory
SBB Register/memory and register to either	1/11	1/40	register/memory
SCAS	11	8/12	8-bit/16-bit
SCAS (repeated n times)	$11+8n$	$8/12+8/12n$	8-bit/16-bit
SHL Register/Memory by 1	5	1/32	register/memory

Table 21. Instruction Set Timing (Continued)

Instruction	Clock Cycles		Comments
	IA186EB	IA188EB	
SHL Register/Memory by CL	1/20	1/24	register/memory
SHL Register/Memory by Count	1/11	1/24	
SHR Register/Memory by 1	1/5	1/24	
SHR Register/Memory by CL	1/20	1/28	
SHR Register/Memory by Count	1/11	1/24	
SS	1	1	–
STC	1	1	–
SUB Immediate from accumulator	1	1	–
SUB Immediate from register/memory	1/11	1/28	register/memory
SUB Register/memory and register to either	1/15	1/40	
STD	1	1	–
STI	1	1	–
STOS	6	8	–
STOS (repeated n times)	6+4n	8+8n	–
TEST Immediate data and accumulator	1	1	–
TEST Immediate data and register/memory	1/16	1/16	register/memory
TEST Register/memory and register	1/12	1/20	register/memory
WAIT	1	1	test_n = 0
XCHG Register with accumulator	2	2	–
XCHG Register/memory with register	3/16	3/20	register/memory
XLAT	16	8	–
XOR Immediate to accumulator	1	1	–
XOR Immediate to register/memory	1/11	1/32	register/memory
XOR Register/memory and register to either	1/16	1/32	register/memory

Innovasic Part Number Cross-Reference

Tables 22 through 24 cross-reference the Innovasic part number with the corresponding Intel part number.

Table 22. Innovasic Part Number Cross-Reference for the PLCC

Innovasic Part Number	Intel Part Number	Package Type	Temperature Grades
IA186EBPLC84IR2 lead free (RoHS-compliant)	EE80C186EB25 EE80C186EB20 EN80C186EB25 EN80C186EB20 EN80C186EB13 N80C186EB25 N80C186EB20 N80C186EB13 TN80C186EB25 TN80C186EB20 TN80C186EB13 N80L186EB16 N80L186EB13 TN80L186EB16 TN80L186EB13 EN80L186EB13	84-Pin PLCC	Commercial and industrial
IA188EBPLC84IR2 lead free (RoHS-compliant)	EE80C188EB25 EE80C188EB20 EE80C188EB13 EN80C188EB25 EN80C188EB20 EN80C188EB13 N80C188EB25 N80C188EB20 N80C188EB13 TN80C188EB25 TN80C188EB20 TN80C188EB13 EE80L188EB16 EN80L188EB13 N80L188EB16 N80L188EB13 TN80L188EB16 TN80L188EB13	84-Pin PLCC	Commercial and industrial

Table 23. Innovasic Part Number Cross-Reference for the PQFP

Innovasic Part Number	Intel Part Number	Package Type	Temperature Grades
IA186EBPQF80IR2 lead free (RoHS-compliant)	EG80C186EB25 ES80C186EB20 ES80C186EB13 S80C186EB25 S80C186EB20 S80C186EB13 TS80C186EB25 TS80C186EB20 TS80C186EB13 EG80L186EB16 EG80L186EB13 S80L186EB16 S80L186EB13 TS80L186EB16 TS80L186EB13	80-Pin PQFP	Commercial and industrial
IA188EBPQF80IR2 lead free (RoHS-compliant)	EG80C188EB25 ES80C188EB20 S80C188EB25 S80C188EB20 S80C188EB13 TS80C188EB25 TS80C188EB20 TS80C188EB13 ES80L188EB13 TS80L188EB16 TS80L188EB13	80-Pin PQFP	Commercial and industrial

Table 24. Innovasic Part Number Cross-Reference for the LQFP

Innovasic Part Number	Intel Part Number	Package Type	Temperature Grades
IA186EBPLQ80IR2 lead free (RoHS-compliant)	YW80C186EB25 YW80C186EB20 SB80C186EB25 SB80C186EB20 SB80C186EB13 YW80L186EB16 YW80L186EB13 SB80L186EB16 SB80L186EB13	80-Pin LQFP	Commercial and industrial
IA188EBPLQ80IR2 lead free (RoHS-compliant)	YW80C188EB25 YW80C188EB20 SB80C188EB25 SB80C188EB20 SB80C188EB13 YW80L188EB16 YW80L188EB13 SB80L188EB16 SB80L188EB13	80-Pin LQFP	Commercial and industrial

9. Errata

The following errata are associated with Version 0 of the IA186EB/IA188EB. A workaround to the identified problem has been provided where possible.

9.1 Summary

Table 25 presents a summary of errata.

Table 25. Summary of Errata

Errata No.	Problem	Ver. 0	Ver. 2
1	Alternate Mode (TxCON[1] == 1) for timer 0 and 1 has some functional issues.	Exists	Fixed
2	When the extension byte (mod field) is set to "11," some instructions will cause the CPU to hang.	Exists	Fixed
3	When the chip is put in SFNM mode for INT0 or INT1, the LVL bit is automatically set for those interrupts.	Exists	Fixed
4	Timer 2 will stop or not start counting.	Exists	Fixed
5	Write does not occur when counter is actively counting.	Exists	Fixed
6	Program Counter can become corrupted if an interrupt occurs.	Exists	Fixed
7	Bound instruction uses bad data when index addresses are on odd boundary in memory.	Exists	Fixed
8	Pin LOCK_n does not have an internal pullup and will float during reset and bus hold.	Exists	Exists
9	The Relocation Register (RELREG, PCB offset 0xA8) can only be modified by an 8-bit write.	Exists	Exists
10	When the timer compare register for any of the timers is set to x0000, the max count is xFFFF instead of x10000 as in the OEM part.	Exists	Exists
11	NMI cannot bring chip out of powerdown mode.	-	Exists

Errata No.	Problem	Ver. 0	Ver. 2
12	Illegal serial port modes do not match OEM part.	Exists	Exists
13	Non-maskable interrupt (NMI) can be pre-empted by maskable interrupt.	Exists	Exists
14	Ready signal may not be recognized in bus cycles with zero wait states.	Exists	Exists

9.2 Detail

Errata No. 1

Problem: Alternate Mode (TxCON[1] == 1) for timer 0 and 1 has some functional issues.

Description:

- TxOUT will continuously toggle at 1/2 CLKOUT regardless of count register values.
- The maxcount compare will not work. The live count will compare against TxCMPA and TxCMPB in alternate cycles. This could cause a compare (and the associated interrupt, or switch the intended compare, or stop counting altogether) to occur early or not at all.
- The TxOUT pin may start in the wrong state if the user writes to TxCON register Bit [12].
- When in retrigger mode, Timer 1 will not function correctly. Input pulses on T0IN will cause counter to begin counting.

Workaround: None.

Errata No. 2

Problem: When the extension byte (mod field) is set to “11,” some instructions will cause the CPU to hang.

Description: Although there are faster versions of each instruction (these are not commonly used by compilers), the following instructions will cause the CPU to hang when the extension byte (mod field) is set to “11”:

- 8D (LEA)
- 8F (POP memory)
- C6 (MOV immediate8 to memory/register)
- C7 (MOV immediate16 to memory/register)
- FE (PUSH memory)
- FF (PUSH memory)

Workaround: Substitute instructions in the following table.

Instruction	Workaround
8D (LEA)	Use MOV register (89 or 8B)
8F (POP memory)	Use POP register (0101_0xxx)
C6 (MOV immediate8 to memory/register)	Use MOV immediate8 to register (1011_0xxx)
C7 (MOV immediate16 to memory/register)	Use MOV immediate16 to register (1011_1xxx)
FE (PUSH memory)	Use PUSH register (0101_0xxx)
FF (PUSH memory)	Use PUSH register (0101_0xxx)

Errata No. 3

Problem: When the chip is put in SFNM mode for INT0 or INT1, the LVL bit is automatically set for those interrupts.

Workaround: None.

Errata No. 4

Problem: Timer 2 will stop or not start counting.

Description: Writing a logic “1” to unused bits in the timer control register can cause the timer to stop counting or to never start counting.

Workaround: Do not write a logic “1” to any unused or reserved bits in the timer control register.

Errata No. 5

Problem: Write does not occur when counter is actively counting.

Description: If a timer incremented its count register to the currently active compare register during a write to that count register, the write would not occur.

Workaround: Do not write count register while that counter is actively counting.

Errata No. 6

Problem: Program Counter can become corrupted if an interrupt occurs.

Description: If an interrupt occurs during the decode stage of a TEST instruction using an opcode of the form 1111_0111_1100_0xxx, the Program Counter could become corrupted upon returning from the interrupt handler.

Workaround: None.

Errata No. 7

Problem: Bound instruction uses bad data when index addresses are on odd boundary in memory.

Description: BOUND instruction will use bad data if index address LSB is a “1” in memory.

Workaround: None.

Errata No. 8

Problem: Pin LOCK_n does not have an internal pullup.

Description: Because Pin LOCK_n does not have an internal pullup, it will float during reset and bus hold.

Workaround: An external pullup may be necessary if there is high external load on the signal.

Errata No. 9

Problem:

The Relocation Register (RELREG, PCB offset 0xA8) can only be modified by an 8-bit write.

Description: The Relocation Register (RELREG, PCB offset 0xA8) can only be modified by an 8-bit write. A 16-bit write will have no effect. The 186 EB is unaffected.

Workaround: Use an 8-bit access to affect the RELREG register.

Errata No. 10

Problem:

When the timer compare register for any of the timers is set to x0000, the max count is xFFFF instead of x10000 as in the OEM part.

Description: The timer output will change one count earlier than it should when the max count is set to x0000.

Workaround: The workaround is application dependent. Please contact Innovasic Technical Support if this erratum is an issue.

Errata No. 11

Problem:

NMI cannot bring chip out of powerdown mode.

Description: Only a reset brings the part out of powerdown after a HLT instruction is executed with the PWRDN bit set in the PWRCON register.

Workaround: Use IDLE instead of PWRDN.

Errata No. 12

Problem:

Illegal serial port modes do not match OEM part.

Description: If the mode bits of the serial control register (S1CON, S0CON) are set to an illegal encoding (0x5, 0x6, or 0x7), the Innovasic part acts as though it were in mode 4. The OEM part acts as if it were in mode 1.

Workaround: Use a valid encoding for serial mode.

Errata No. 13

Problem:

Non-maskable interrupt (NMI) can be pre-empted by maskable interrupt.

Description: When instruction execution unit is in Decode state for 2 or more consecutive cycles and an NMI is recognized, it could be pre-empted by a maskable interrupt.

Workaround: None.

Errata No. 14

Problem:

Ready signal may not be recognized in bus cycles with zero wait states.

Description: When a chip select is set to use the ready signal to extend a bus cycle that normally has no wait states (Start register bits 3-0 == 0000), the ready signal may not be recognized in time to extend the bus cycle.

Workaround: Set wait states to 1 or more if using ready to extend bus cycles.

Revision History

Table 26 presents the sequence of revisions to document IA211080314.

Table 26. Revision History

Date	Revision	Description	Page(s)
July 30, 2008	00	First edition released.	NA
October 13, 2008	01	Pin number range “ad15–a8” corrected to “a15–a8” in Figures 26 and 27. Errata No. 4 added. [Also cover page, header, footer, and errata chapter reformatted to meet publication standards.]	66, 67, 78, 79, 80, 81
January 14, 2009	02	Updated errata table for Version 00 – added 3 errata (#5 – 7).	81, 83
March 29, 2009	03	Updated instruction set timing for 186EB; Changed 188EB column to TBD pending completion of new tests; Updated Table 9 ratings; Updated Table 11 parameters and ratings; Removed Figures 16 and 17, and reordered subsequent figures; Updates Table 18 ratings and notes; Updated Table 19 parameters, ratings and notes.	42, 43, 55, 56, 68-72
April 24, 2009	04	Added availability of a non-RoHS compliant version of the 188EB in the 80-pin LQFP package. Added two errata for Version 2 of the device. Noted that all other errata have been fixed in Version 2.	75, 76, 79
May 5, 2009	05	Noted the test conditions used to derive the values in Tables 13 -16; Noted that the Instruction Set Timing in Table 21 applies to all versions of the parts.	51, 68
May 18, 2009	06	Updated Figures 4, 5 and 10. Updated Tables 3, 4, 6, 7, 8, 12. Updated Table 21 to provide revised instruction set timing for the 186EB and to add instruction set timing for the 188EB, based on the most recent test results.	15-18, 23, 25-41, 45, 48, 50, 68-72
June 4, 2009	07	Updated V_{OH} parameter on Table 11; corrected labels on Figures 20-21; Added Errata 10.	43, 61, 62, 80

Date	Revision	Description	Page(s)
September 4, 2009	08	Added a note to Table 12 regarding the Step ID register.	50
February 25, 2011	09	Elimination of pages with SnPb lead plating options	74-76
March 23, 2011	10	Updated Instruction Set Timing Table to incorporate DIV and IDIV values.	70
June 12, 2011	11	Added Errata 11 and 12.	77, 78, 81
July 5, 2011	12	Added Errata 13.	78, 82
July 10, 2011	13	Added Errata 14.	78, 82

10. For Additional Information

The Innovasic Semiconductor IA186EB and IA188EB microcontrollers are form, fit, and function replacements for the original Intel® 80C186EB, 80C188EB, 80L186EB, and 80L188EB 16-bit high-integration embedded processors.

The Innovasic Support Team wants our information to be complete, accurate, useful, and easy to understand. Please feel free to contact our experts at Innovasic at any time with suggestions, comments, or questions.

Innovasic Support Team
3737 Princeton NE
Suite 130
Albuquerque, NM 87107

(505) 883-5263
Fax: (505) 883-5477
Toll Free: (888) 824-4184
E-mail: support@innovasic.com
Website: <http://www.Innovasic.com>