

THIS DRAWING IS UNPUBLISHED. RELEASED FOR PUBLICATION, 19 .  
 © COPYRIGHT 19 BY AMP INCORPORATED. ALL RIGHTS RESERVED.

| LOC | DIST | REVISIONS   |                             |      |       |
|-----|------|-------------|-----------------------------|------|-------|
| P   | LTR  | DESCRIPTION | DATE                        | DWN  | APVD  |
| DF  | SO   | E           | REV & REDRAWN; 0600-4612-95 | 6-96 | CT SG |

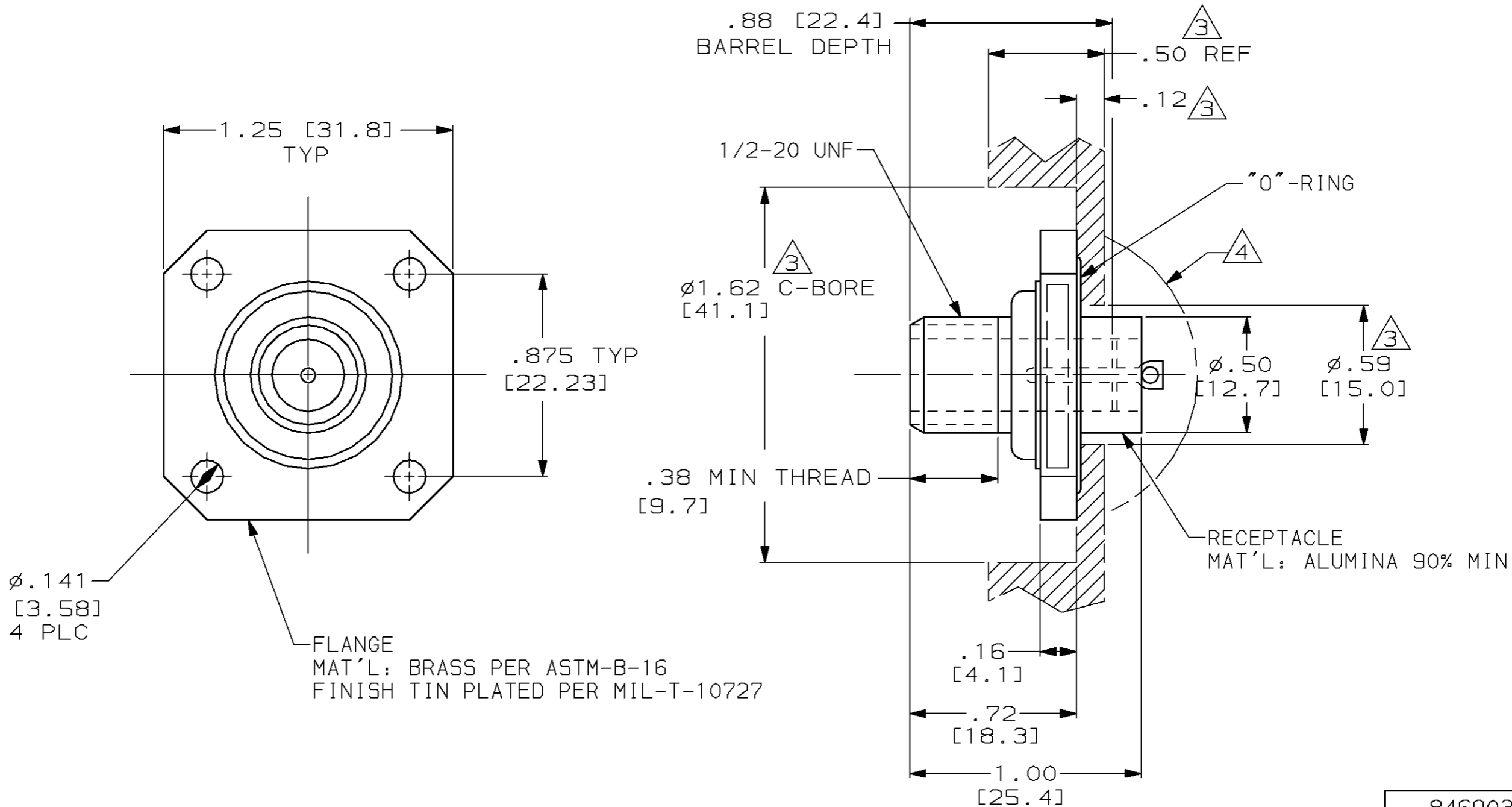

FLANGE  
 MAT'L: BRASS PER ASTM-B-16  
 FINISH TIN PLATED PER MIL-T-10727

RECEPTACLE  
 MAT'L: ALUMINA 90% MIN

846903-1  
 PART NO.

- RECEPTACLE TO MATE WITH AMP RFI SHIELDED LGH-1 LEAD ASSY.
- MARKED PER MIL-STD-130.
- CUSTOMER BULKHEAD MOUNTING DIMENSIONS.
- CUSTOMER TO PROTECT THIS END AGAINST VOLTAGE BREAKDOWN.

|  |  |                                 |  |
|--|--|---------------------------------|--|
| THIS DRAWING IS A CONTROLLED DOCUMENT. |  | DWN<br>C.C. THOMAS<br>6-14-96   | <b>AMP</b> AMP Incorporated<br>Harrisburg, PA 17105-3608 |
|  |  | CHK<br>S. GLATFELTER<br>7-8-96  |  |
|  |  | APVD<br>S. GLATFELTER<br>7-8-96 | NAME   |
|  |  | PRODUCT SPEC                    | FLANGED RECPTACLE ASSY, LGH-1                            |
|  |  | APPLICATION SPEC                |  |
|  |  | WEIGHT                          |  |
|  |  | CUSTOMER DRAWING                |  |
|  |  | SIZE<br>A3                      | CAGE CODE<br>00779                                       |
|  |  | DRAWING NO<br>C-846903          |  |
|  |  | SCALE<br>2:1                    | SHEET<br>1 OF 1  |
|  |  | REV<br>E                        |  |

| DIMENSIONS, INCHES [mm] | TOLERANCES UNLESS OTHERWISE SPECIFIED. |
|-------------------------|--|
| 0 PLC                   | ±-                                     |
| 1 PLC                   | ±-                                     |
| 2 PLC                   | ±.02 [0.5]                             |
| 3 PLC                   | ±.005 [0.13]                           |
| 4 PLC                   | ±-                                     |
| ANGLES                  | ±-                                     |
| MATERIAL                | FINISH                                 |
| -                       | -                                      |